

CABINET Handbook

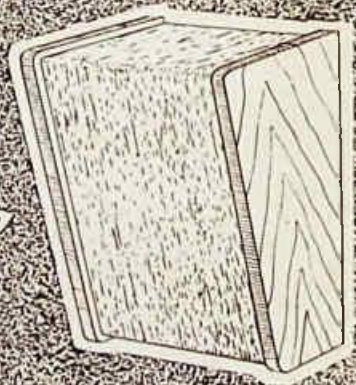

G.A. BRIGGS

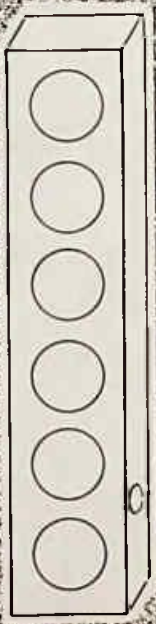

R
B

Historie v/d Radio

BIBLIOTHEEK
N.V.H.B.

CABINET HANDBOOK

FIRST EDITION

MAY 1962

Copyright
Registered at Stationers' Hall.

Made and Printed in England by Tapp & Toothill Ltd., Leeds and London

CABINET HANDBOOK

by

G. A. BRIGGS

AUTHOR OF

- "LOUDSPEAKERS"
- "SOUND REPRODUCTION"
- "PIANOS, PIANISTS AND SONICS"
- "AMPLIFIERS"
- * "HIGH FIDELITY"
- * "STEREO HANDBOOK"
- * "A TO Z IN AUDIO"
- "AUDIO BIOGRAPHIES"

* *With R. E. COOKE as Technical Editor*

Published by WHARFEDALE WIRELESS WORKS LIMITED
IDLE :: BRADFORD :: YORKSHIRE

Dedicated to Audiophiles and "Do it yourself" stalwarts, this book deals with the design and construction of loudspeaker cabinets, and also outlines the acoustic principles involved in obtaining satisfactory results, especially with compact enclosures.

CONTENTS

	<i>Page</i>
Bibliography	6
Introduction	7
Chap. 1 Materials	9
„ 2 Plywood	18
„ 3 Adhesives	26
„ 4 Veneering	29
„ 5 Machines	36
„ 6 Assembly	42
„ 7 Polishing	47
„ 8 Mesh	53
„ 9 Resonance	57
„ 10 Absorbents	61
„ 11 Home Equipment	72
„ 12 Cabinet Design	75
„ 13 Treble Enclosures	97
„ 14 Electric Guitars	101
„ 15 Room Treatment	104
Conclusion	110
Index	111

BIBLIOGRAPHY

As there are over 150 publications in circulation on subjects associated with timber, plywood and their uses, anything approaching a complete bibliography would be utterly confusing to the reader. We therefore content ourselves by listing here seven books or bulletins which we have found useful and which would be helpful to those who may wish to delve more deeply into the various subjects.

The Practical Carpenter and Joiner.

Revised Edition 1961, 448 pp. 21/-.

Published by Odhams Press Ltd., London.

A comprehensive book packed with facts, figures, instructions and illustrations.

General Woodworking.

C. H. Groneman. 2nd Edition, 248 pp. 38/6.

Published by McGraw-Hill Book Co. Inc., New York.

Beautifully printed in two colours by the offset process extensively used in America. Profusely illustrated.

Plywood.

Revised January 1961. 48 pp. 5/-.

Published by Timber Development Association, 21 College Hill, London, E.C.4.

Authentic information on manufacture, grades and use.

Requirements and Properties of Adhesives for Wood.

R. A. G. Knight. 3rd Edition, 1956, 24 pp. 2/-.

Forest Products Research, Bulletin No. 20.

Published by H.M. Stationery Office.

Concise details of constitution and use of modern adhesives.

Veneering.

E. W. Hobbs. Revised 1953, 136 pp. 4/6.

Published by Cassell & Co. Ltd., London.

A handy little book—well illustrated.

Staining and Polishing.

C. H. Hayward. Reprinted 1959, 214 pp. 15/-.

Published by Evans Bros. Ltd., London.

The art of polishing thoroughly explained.

Sound Absorbing Materials.

Evans & Bazley. N.P.L. 1960, 50 pp. 3/-.

Published by H.M. Stationery Office.

Authentic facts and figures at less than a penny per page.

INTRODUCTION

It is customary for hi-fi speaker makers in this country and America to supply Cabinet Construction Sheets free of charge. (We actually dispose of 20,000 copies of an eight-page C.C.S. in one year.) In view of this, it might appear that a book with a price on it would meet with little demand, but there are many aspects of loudspeaker mounting, especially in compact enclosures, which have not hitherto been explained to users in general, and there is much to be written about construction, lining, mesh fitting, veneering and polishing.

So far as cabinet design is concerned, including absorbents and crossover networks which are often an integral part thereof, our object has been to explain the principles involved rather than design a cabinet for a specific unit. Thus the book should have a wider appeal and should facilitate the use of speakers of different makes and types.

As to woodworking in general, I thought it would be useful to find out how many books on allied subjects were already in circulation, so Mr. Eric Barker—who is aiding and abetting my efforts—paid a visit to W. H. Smith's new emporium in Bradford and picked up half-a-dozen books in about as many minutes. (There was nobody about at the time!)

I then wrote to the Chief Librarian in Bradford and he gave me the following astonishing summary, which includes some duplications:

BOOKS on Woodworking in Central Library

	<i>Reference Library</i>	<i>Lending Library</i>
Carpentry ...	65	103
Cabinet making ...	10	16
Polishing ...	5	5
Veneering ...	3	2
Timber ...	25	6
Plywood ...	3	1
	<hr/>	<hr/>
	111	133

Grand total 244.

With such prolific sources of information available, the only excuse for a further book on the subject is that we are dealing with the specific application of cabinet work to loudspeakers and sound reproduction in rooms.

It is still a sound idea to have the loudspeakers specially housed, so that they are acoustically isolated from turntable and pickup and the best room placement can be found and used.

To conclude this foreword, I ought to explain that the production of a book of this nature is very much a concerted effort involving the knocking up of dozens of samples and the making of many tests of response, impedance, resonance and distortion, with a careful listening test as the final arbiter of loudspeaker performance. Although I do the pen-pushing, I acknowledge with pleasure the valiant support I have had from the following protagonists:

Mr. Eric Barker for general assistance and for doing most of the drawings.

Mr. Ralph White, manager of our cabinet works, and his staff for prompt production of countless samples for test.

Mr. K. F. Russell, our technical manager, and his assistant Mr. W. Jamieson, along with our works manager Mr. E. R. Broadley, for loudspeaker tests.

Finally, to the South of England and my thanks to Mr. James Moir for his work on *Absorbents* and for vetting the chapter on *Room Treatment*.

March 1962.

G. A. B.

CHAPTER 1

MATERIALS

Acoustically speaking, a good motto for cabinets is "the denser the better", so in this respect they may be said to differ somewhat from human beings. Almost any rigid material can be used, but wood is still the most popular both for ease of production and final appearance.

DENSITY

Following the above motto, we cannot do better than begin by giving a table of density figures for most of the materials with which we are familiar, although it is obvious that the use of thicker panels is to some extent equivalent to higher density.

DENSITY TABLE, gm/cc

<i>Material</i>		<i>Material</i>	
Expanded polystyrene	·02/·15	Marble 2·6
Cork 25	Granite 2·7
Celotex 32	Aluminium 2·7
Pine 45	Quartz 2·7
Walnut 56	Slate 2·9
Beech 65	Mazak, cast 6·0
Mahogany 67	Nickel 6·8
Plywood 67	Zinc 7·1
Maple 68	Tin 7·3
Oak 72	Steel 7·7
Weyroc or Chipboard 81	Iron 7·8
Paper 1·0	Brass 8·4
Cellulose acetate 1·3	Copper 8·6
Dry Sand 1·5	Cadmium 8·6
Shellac 1·7	Cobalt 8·7
Brick 1·8	Silver 10·6
Tiles 2·0	Lead 11·3
Glass 2·4	Tungsten 19·0
Porcelain 2·4	Gold 19·3
Concrete 2·6	Platinum 21·4

It is interesting to note here that as a general rule the materials with the highest density have the lowest absorption coefficient, but it must be remembered that in some materials absorption varies enormously with frequency.

Although the main subject matter of this book is devoted to cabinets made of wood, I think it is important that readers should keep an open mind and use their imagination as occasion arises, falling back on the compact bookshelf device only as, when and where necessary. We will therefore deal with the heavy stuff first,

MATERIALS

giving examples of its use from time to time during our 28 years of weight-lifting experiences, allied of course to sound reproduction.

Plywood is given a chapter on its own, as it is easily the most important medium for cabinet making.

BRICKS AND MORTAR

It must have been in 1946 that we built our first 9 cu.ft. corner enclosure in bricks, and I still rate this medium as highly as ever. We naturally spend quite a lot of time comparing different speakers, and most of them sound either anæmic or "coloured" when matched up to the bricks and mortar. There are obviously very solid reasons for this, and one reason for maximum bass, which is easily overlooked when making tests and comparisons, is that a speaker built into the corner of a room is in the optimum LF position—and stays there.

MARBLE

Almost equally good acoustically, and more handsome in appearance, is a marble panel. We made a couple about ten years ago and I still use one at home—photographed in Fig. 1/1.

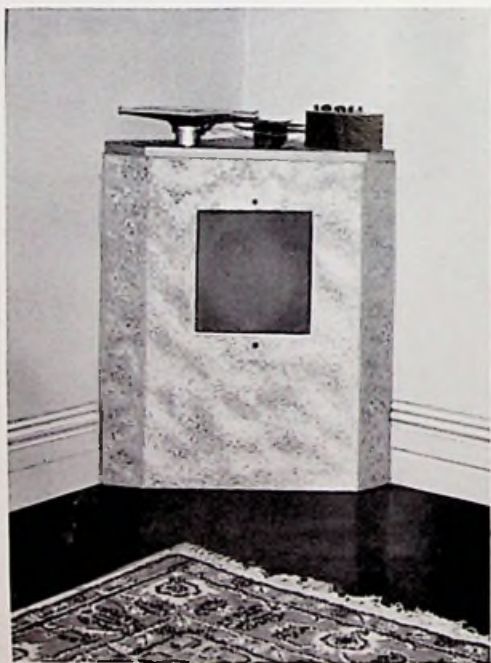

FIG. 1/1. *Corner panel in marble, $\frac{3}{4}$ " thick.*

We did not pursue the marble plan because the panels are brittle and break like slabs of chocolate if dropped. However, once *in situ* the marble is fine and I have no intention of parting company with mine so long as my ears are functioning reasonably well.

CONCRETE

This has the same density as marble, and can be moulded in different shapes. Concrete columns and drainpipes have been adapted with success for use with 8" and 10" speakers and full details are given in a previous book: *A to Z in Audio*.

With 12" speakers, columns are not satisfactory unless very large. That they can be made to look attractive is shown in a photograph sent to me recently by Mr. Robert R. Lyall of P.O. Mataffin, E. Transvaal, S.A., and reproduced in Fig. 1/2.

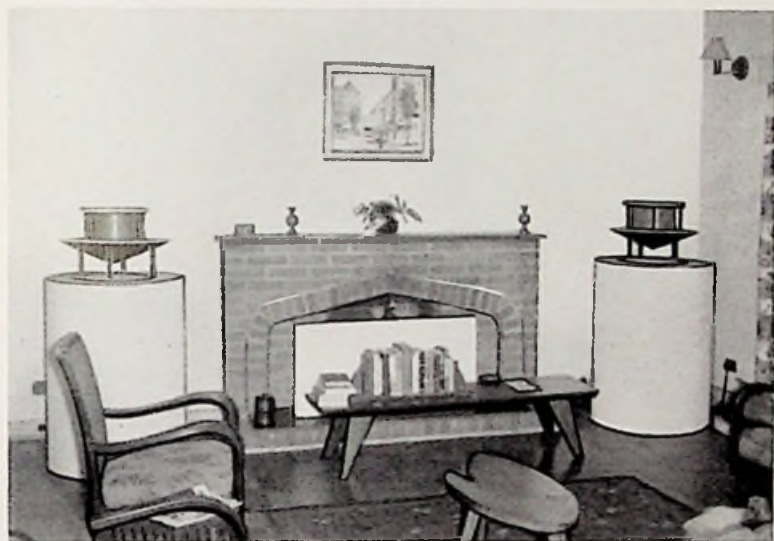

FIG. 1/2. Stereo speaker systems using 12" and 8" units with omni-directional effects.

The asbestos cement pipes are 3 ft. long and 2 ft. inside diameter, weighing approximately 400 lb. each, giving 9 cu.ft. volume of air loading. The cement is $1\frac{1}{8}$ " thick and the vent opening in each pipe is 40 sq.in.

Mounted above the 12" units are solid asbestos cement diffusers, and above these are the 8" units on circular baffles with open mesh at the sides and top.

A normal crossover network is used and Mr. Lyall reports that

MATERIALS

results are very gratifying after the heavy work involved. Incidentally, no absorbents or linings are used inside the enclosures.

CERAMICS

One of the best speaker enclosures we ever tried in the $\frac{2}{3}$ cu.ft. range was made from an old kitchen sink. The entire absence of structural resonance came as a revelation some 15 years ago. Today we use ceramic tiles in some cabinets for reducing panel resonance, as shown in Fig. 1/3. PVA adhesive is effective here.

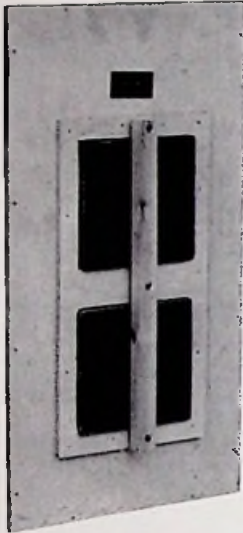
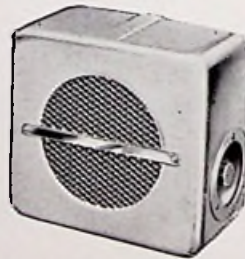

FIG. 1/3.
*Ceramic tiles glued
and battened to cab-
inet back to subdue
resonance.*

METAL

About the end of the war, when plywood was almost unobtainable, we made a small extension speaker out of sheet metal, enamelled in various colours, which we named the "Tiny". This is illustrated in Fig. 1/4.

FIG. 1/4.
*Small extension speaker circa
1945 in sheet metal—acousti-
cally very good.*



I remember feeling rather dubious about adopting the name Tiny for this model, as I was afraid some users would write in and say results were tinny, but we had no complaints because the gauge of metal was more than adequate for the size, and the reproduction was brighter and clearer than that obtained from an equivalent plywood cabinet. But this is not to be wondered at when we remember that iron and steel have a density figure in excess of 7.

Then, a few years ago, we made a baffle in $\frac{1}{4}$ " Dural with plywood sides as per drawing in Fig. 1/5.

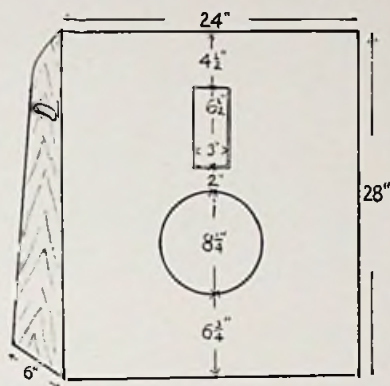

FIG. 1/5.
Metal baffle, for 10" and 8"
units in parallel. Weight of
panel, 17 lb.

The 8" unit was fronted with a slot diffuser to improve radiation in the treble. We unearthed this model from our discarded designs store for a fresh listening test for this book and I was astonished at the clean, resonance-free results. I can assure readers that the open baffle is far from obsolete.

A rather wider frequency response can be achieved by using a 12" and a 5" unit in parallel, with possibly a 24 Mfd capacitor in series with the smaller speaker. The baffle openings would then be about 10" diameter for the big speaker and a slot 4" x 1" for treble dispersal.

DE LUXE EFFORT

The materials mentioned so far are all reasonably priced. If you really want to go one better than the Jones's, your choice should be platinum with gold trimmings; the densest possible combination.

RESONANCE

The main virtue of all these high density materials is, in simple terms, that they reflect sound waves to be heard in the listening room, instead of absorbing some frequencies and colouring others by dithering themselves.

MATERIALS

EXPANDED POLYSTYRENE

There is generally an exception to every rule, and expanded polystyrene almost disproves the rule about the value of density in cabinet structure—but not quite. In spite of being extremely light it is virtually free from resonance. It acts as a good insulator at high frequencies (and is often used as an ice cream pack) but low frequencies tend to pass through it, resulting in severe loss of bass if used alone for cabinet construction. We have overcome the problem in one model by fitting the expanded polystyrene in a solid wood frame, and then covering one side with $\frac{1}{8}$ " plywood and the other with $\frac{1}{8}$ " hardboard, thus producing a light, resonance-free panel, but costly in terms of labour. Fig. 1/6 shows the construction, with a layer of bonded acetate fibre on the inside face of the panel.



FIG. 1/6. Panel with $\frac{3}{4}$ " expanded polystyrene, covered $\frac{1}{8}$ " plywood outside and $\frac{1}{8}$ " hardboard inside. Also 1" interior absorbent lining.

Patent application No. 35728/58.

The panels must be well glued together to avoid vibration and care must be exercised in the choice of adhesives as many of them destroy the polystyrene. The most suitable are the PVA types, which incidentally are cold setting.

Expanded polystyrene has some valuable applications in loud-speaker diaphragms and its use as an acoustic filter with 12" units in small enclosures is described in Chapter 10.

CHIPBOARD

Weyroc or chipboard is a good material, denser than plywood, but it is very hard and is more difficult to manipulate. It is available today ready veneered, and can be strongly recommended for use with sharp tools.

SOLID WOOD

Timber can be divided into two classes, hardwood and softwood, the best known being the following:

HARDWOODS

Ash, beech, birch, canary, elm, gaboan, mahogany, maple, oak, obeche, poplar, ramin, sycamore, teak and walnut. (For readers really interested in the subject, *A Handbook of Hardwoods* published by H.M. Stationery Office at 17s. 6d. deals fully with 151 timbers and briefly with another 64.)

SOFTWOODS

Cedar, Douglas fir, hemlock, larch, pine, redwood, spruce and whitewood.

Hardwood is used for external frame work, bars, etc., and no doubt the perfectionist will insist on using solid oak with oak veneers, walnut with walnut, and so on, but the important thing is to find a solid wood which does not bend and split too easily, and can be stained to match a veneered panel, or finished lighter or darker for relief.

Softwood is used for internal jobs such as glue blocks and back rails. The choice of timber here is not important; we find pine as good as any of the others.

CONDITION OF TIMBER

The moisture content is of very great importance, and we usually try to work with timber about 12/14% M.C., tests being made with the instrument shown in Fig. 1/7 which is controlled by the resistance of the wood.



FIG. 1/7.
*Instrument for checking
moisture content.*

MATERIALS

The interesting graphs of Fig. 1/8 (from *The Practical Carpenter and Joiner*) show that seasoning brings the moisture content down by as much as 10%, and conditions of use down to an average of 12% M.C. with a constant increase in shrinkage.

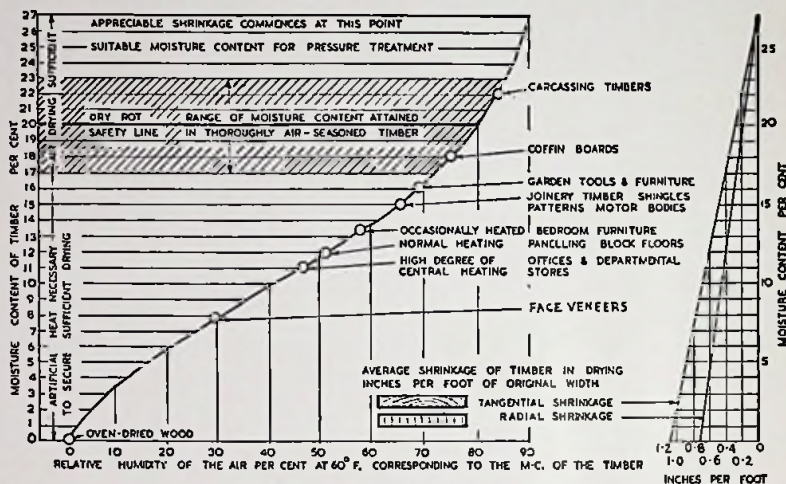

Courtesy Odhams Press Ltd.

FIG. 1/8. *Moisture content of timber under various conditions, with degree of shrinkage on right.*

PESTS

Dry rot, paradoxically, only sets in when timber is moist and lacking ventilation, and is caused by a fungus *mercurius lacrymans* (presumably because it brings tears to the eyes of those whose property it attacks).

Wood worm, or the Furniture Beetle (*anobium punctatum*) leaves little holes about $\frac{3}{16}$ " wide in its trail, but is not so infectious as dry rot, and damaged parts can be cut off and replaced. The Death-watch Beetle is similar but slightly larger. Attacks from these insects can be prevented by filling up cracks and waxing all unpolished parts. They do not as a rule eat into plywood—presumably because they do not like the taste of glue. Another pest is the Powder-post Beetle, but this only attacks the sapwood.

According to Boulton & Jay, if damage is present, watch should be kept for the beetles during spring and summer and they must be killed by turpentine, benzene, creosote or one of the proprietary compounds. To enable readers to recognise the marauders they are pictured in Fig. 1/9.

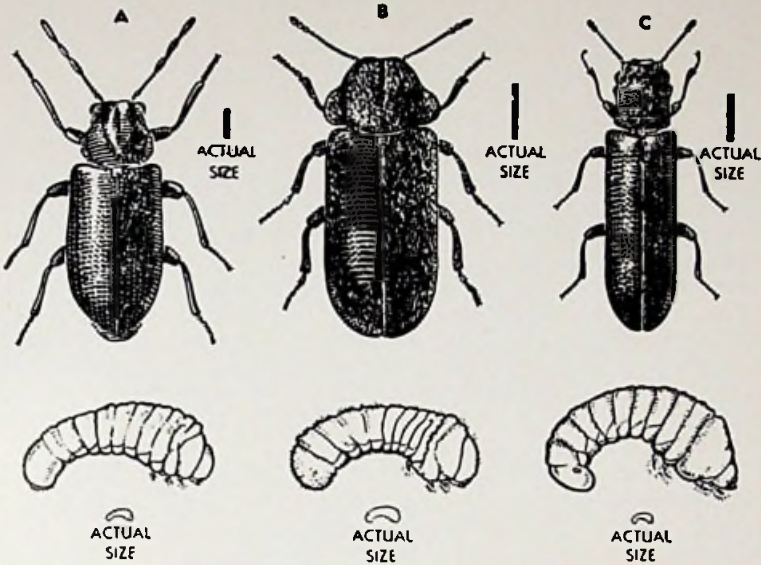

From *The Practical Carpenter and Joiner*, Odhams Press Ltd.

FIG. 1/9. *The three main wood-destroying insects found in Britain, with their off-spring.*

A — Furniture beetle or wood worm.

B — Death-watch beetle.

C — Powder-post beetle.

The small symbols indicate the actual size of the insects and larvae.

CHAPTER 2

PLYWOOD

Plywood is used extensively for cabinet making, not because it is cheap, but because it retains its shape, is easy to cut and manipulate, has a high strength/weight ratio, is available in many sizes and types, and can be finished or veneered in countless ways. In fact, plywood is just about as versatile for cabinet work as the moving-coil speaker is for reproducing sound, which is more than a little.

One of the most informative books on the subject is *Plywood*, published at 5s. by the Timber Development Association and listed in the Bibliography at the beginning of this book. The facts relating to the properties of plywood, its manufacture, adhesives used, sizes, types, applications, etc., are all there, concisely stated, with details of producing countries and surface quality.

Timber being a non-homogeneous and hygroscopic material is comparatively weak across the grain, and shrinks and swells under varying degrees of temperature and humidity, the movement also taking place across the grain. The cross-banding of the layers in plywood helps to overcome these weaknesses and much greater stability is thus achieved.

TYPES OF PLYWOOD

The BS 565 definition of plywood reads as follows:

“An assembled product made up of plies and adhesives, the chief characteristics being the crossed layers which distribute the longitudinal wood strength. Boards formed of more than three plies are usually designated multiply.”

The plywood is balanced by using an odd number of veneers or layers, 3, 5, 7, 9, 11, etc., according to thickness, but the actual number of plies is of only secondary importance. For instance, we use $\frac{3}{8}$ " birch ply with 13 layers for many jobs, but our $\frac{5}{8}$ " tropical plywood costs about 33% more and consists of only 7 layers. (This we use only for exports to tropical countries.)

Where a thickness of an inch or so is required, blockboard may be used, with variations known as laminboard and battenboard as shown in Fig. 2/1.

Acoustically, there is not much difference between plywood and blockboard of the same total thickness. The thickness to be used is of course determined by the size of the panel or cabinet. At one inch thick, $\frac{1}{2}$ " ply with $\frac{1}{2}$ " Celotex or building board glued together

PLYWOOD

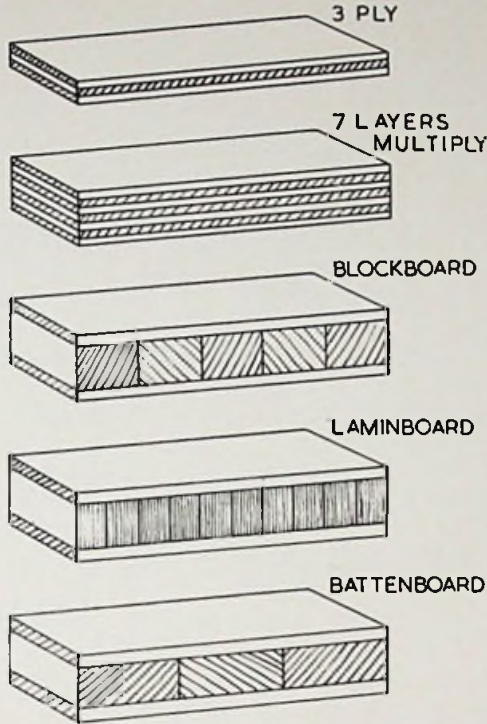

FIG. 2/1.
*Examples of
plywood and block-
board assembly.*

would be superior to blockboard, and two layers of $\frac{1}{4}$ " ply with $\frac{1}{2}$ " sand between them would be better still.

In the T.D.A. book already mentioned, no less than 26 different timbers are listed as being used in manufacture in many countries, ranging in alphabetical order from Alder and Birch via Gaboon and Mahogany to Pine and finally Utile (of which I have never previously heard).

For our purposes, I do not think we can improve on birch ply which is freely available from Finland and Russia at reasonable prices, or Cresta ply from Nigeria when tropical conditions are involved. (In the U.S.A. and Canada, Douglas Fir would answer for both tropical and temperate climes, as it is normally produced WBP, which means weather and boil-proof.)

MANUFACTURE

There are two main methods of cutting the veneer: A—by rotary cutting, known as peeling, and B—by slicing. These are neatly illustrated in Fig. 2/2 taken from *The Practical Carpenter and Joiner*.

PLYWOOD

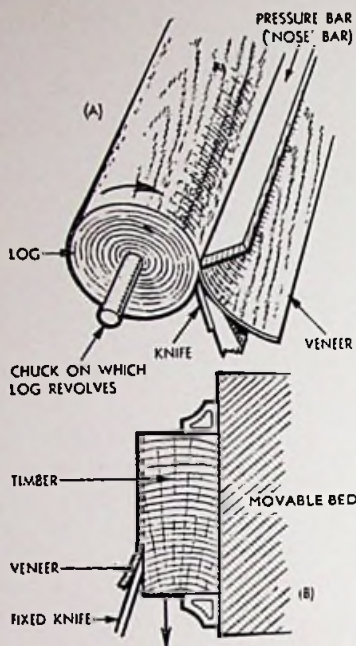

FIG. 2/2.
Methods of cutting veneer for plywood:

A—Rotary cutter.

B—Vertical slicer.

Courtesy
Odhams Press Ltd.

By far the most common is peeling, as this enables large sheets of plywood to be produced without jointing. With certain timbers, especially those with figured grain and burrs, slicing is adopted and this may be done horizontally or vertically. Some tropical plywoods with fairly thick laminations are obviously produced by slicing, shown by the joints on the facing veneers.

GRADING

Finnish birch is classified as follows, all sanded on two sides except the WG faces:

- A Practically free from all defects.
- B Some small pin knots and natural defects allowed. Unjointed.
- BJ Similar to B but jointed.
- BB Well-made plugs and joints permitted.
- WG All defects allowed; only guaranteed to be well glued.

Naturally, the price varies according to grade, and there is a choice of combination as follows (ignoring A which is hardly necessary for good commercial standards).



FIG. 2/3. *Grade BB birch plywood, showing permitted plugs and small knots.*

FINNISH BIRCH

Grades commonly used:

- B 1st Grade both sides.
- B/BB 1st Grade one side; plugs one side.
- BB Plugs both sides.
- BB/WG Plugs one side; knots one side.

For commercial purposes, B/BB is a pretty good stand-by. The plugs are oval inserts which replace large and rough knots and other surface faults, as shown in Fig. 2/3.

In America, fir plywood is produced in four grades, A, B, C and D, and is described as Sound 1 Side and Sound 2 Sides. If you order A—A you have a flawless face on both sides, or with A—D you have the best grade on one side with the poorest on the back. Another designation for better quality plywood is G2S meaning Good 2 Sides, or G1S meaning Good 1 Side.

As it is difficult to see inside a radio or loudspeaker cabinet, there is no point in spending good money on G2S plywood, as it does not affect durability or acoustic quality.

ADHESIVES

Many types and mixtures are used in plywood, and they are grouped in order of durability under the headings INT, MR, BR and WBP, which can be briefly described as follows:

INT=INTERIOR

Animal Glues. Excellent bond under dry conditions of use. Not resistant to water or micro-organisms.

Blood Albumen. Moderate bond with high resistance to even boiling water. Liable to attack by micro-organisms.

Casein and Soya. Strong bond in a dry state only.

MR=MOISTURE RESISTANT

Urea-formaldehyde. Urea resins provide a strong bond in dry and wet state, but not in boiling water or severe tropical conditions. Immune to micro-organisms and resistant to acids and alkalis.

BR=BOIL RESISTANT

Melamine-formaldehyde. A new adhesive, sometimes combined with urea resins to increase resistance to boiling water. Immune to micro-organisms.

WBP=WEATHER AND BOIL-PROOF

Phenol and Resorcinal formaldehyde. These phenolic and RF resins are resistant to all conditions of exposure, including tropics, micro-organisms, acids, etc. In fact, the WBP bonding substance is in every way more durable than the veneers or layers which it holds together.

PLYWOOD TEST

Having read somewhere that the standard Air Ministry test for plywood is to boil it in water for three hours, douche it in cold water, dry it out and see how it survives the ordeal, I took some samples and gave them to Nellie, our head cook, and asked her to try to make them into soup. There were three pieces each $6'' \times 6'' \times \frac{5}{8}''$:

- (a) Finnish birch, 13 ply;
- (b) Cresta tropical, 7 ply;
- (c) Ramin solid hardwood.

After three hours boiling, the samples all came out of the pan looking no worse for the treatment, but when dried out, the solid wood was warped and showed a few fine cracks; the birch ply could be split along a glue line by being hit with hammer and chisel, but the tropical ply retained all its original powers of cohesion. The photograph of Fig. 2/4 shows the result of these splitting tests.

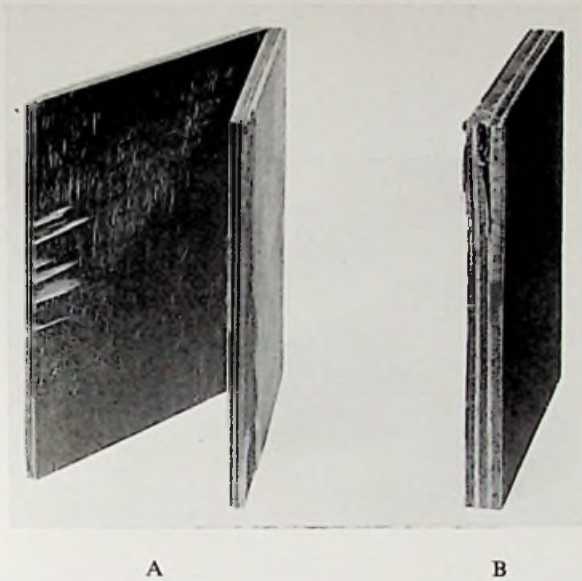

FIG. 2/4. Results of 3-hour boiling test.
 (A) Birch ply split in two by hammer and chisel attack.
 (B) Tropical ply after resisting the same attack.

For my part, I was agreeably surprised by the way the ordinary plywood went through this rather severe test, and nobody need hesitate to use it for indoor cabinet work in non-tropical countries. The WBP tropical ply should be used for hot and humid environments (and, of course, for outdoor work).

Solid wood should only be used for frame work, rails and glue blocks where it is secured against warping or bending. Most timber is kiln dried today, and this has not the virtue of long, drawn-out open air seasoning.

The photograph in Fig. 2/5 shows the process of preparing WBP Finnish birch veneers for the presses, and was sent to us by the Finnish Plywood Development Association, 38 King William Street, London, E.C.4, who are always ready to supply technical data and information on the use of the Finnish national product.

DURABILITY

Nobody need worry about the reliability of plywood under normal conditions of use.

In Fig. 2/6 we see front and back views of the first cabinet speaker we produced in 1933. Although it needs repolishing, the plywood and joints are still perfectly sound.

PLYWOOD



FIG. 2/5. *Phenolic resin glueing of veneers in Finland for tropical plywood.*

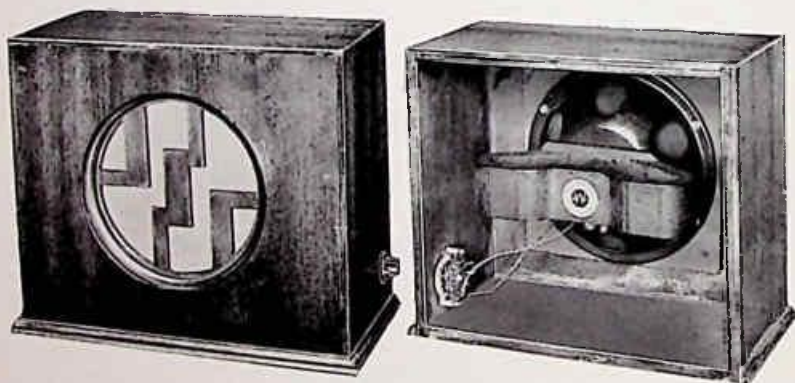

FIG. 2/6. *Cabinet speaker made in 1933 and still sound in wind and limb.*

The most remarkable thing about this museum piece is the 28-year-old chrome magnet made in Sheffield, with a flux density of 7,000 lines in the gap. Tested in September, 1961—without having

been remagnetised—the reading was 6,370, which speaks well for the permanency of the permanent magnet.

SIZE AND THICKNESS

Plywood is available in many sizes, varying from 36" to 96" long and 36" to 72" in width, the grain of the face running parallel to the long dimension. When ordering plywood it should be remembered that the first dimension quoted indicates the length. 60" × 58" seems to be a convenient and popular size for cabinet work.

Most timber merchants will cut and supply panels to a specified size, but if hardboard, Beaverboard or Celotex is also required they may sell these only in standard sheets.

Thickness normally runs from $\frac{1}{8}$ " to $\frac{3}{4}$ " in plywood, or thicker in blockboard. Continental brands are always quoted in metric measure, but English and American makers use inches.

The following table gives the equivalents in inches and millimetres:

<i>Inch</i>	<i>mm</i>
$\frac{1}{8}$	3.17
$\frac{3}{16}$	4.76
$\frac{1}{4}$	6.35
$\frac{3}{8}$	9.52
$\frac{1}{2}$	12.70
$\frac{5}{8}$	15.87
$\frac{3}{4}$	19.05
1	25.40

Naturally, nobody bothers about decimal points in measuring the thickness of plywood as slight variations often occur. If you were looking for $\frac{1}{4}$ " ply, you would take 6 mm, and most buyers would take 12 mm for $\frac{1}{2}$ " requirements.

VENEERED PLYWOOD

Plywood can be bought already veneered in standard walnut, oak, mahogany, etc., although the choice of size and thickness will be restricted compared with plain birch and other white woods.

Plastic-face veneers and various metals are also used on plywood and are quite satisfactory in the acoustic sense.

STORAGE

Plywood should be kept in a dry place and stacked flat, one sheet on top of another, the ideal being to maintain the moisture content at 10 to 12%.

CHAPTER 3

ADHESIVES

During the last 30 years, enormous progress has been made in the development of adhesives for specific purposes and the manufacturers are prepared to tackle any sticky problem from fixing metal to metal, rubber to plastics, tiles to walls and wood to almost anything. In fact, I would say that adhesives for wood are numerous and plentiful.

We have already had a summary of the types used in the manufacture of plywood, but the requirements for cabinet assembly work at home are less exacting, unless tropical conditions are involved, necessitating a more careful choice. Normally, we need only look for adhesives which do not stain or colour the wood, are easily applied, and then set neither too slowly nor too quickly for the job in hand. A fourth proviso for the amateur is that the recommended type should be obtainable through retail channels. In order to test the supply situation, I went to an ironmonger's shop in Ilkley (where I live) and bought a sample of each adhesive which was on sale. I was agreeably surprised when I came out with no less than 22 varieties at a total cost of 45s. We photographed them (Fig. 3/1) just for the record. Plenty of instructions for use are given and these should be carefully observed, especially with inflammable types.

Other varieties would be available from woodworking and hobby shops, timber merchants, large stores, etc., and I feel sure that if we recommend in this book the type of glue required for a certain job, the reader will have no difficulty in finding an equivalent. For general purposes, the electrically heated glue pot is still a good stand-by and results in very little waste as the contents can be reheated.

Tubes. Although adhesives cost more in tubes than in larger containers, they are often more economical in use because wastage is virtually eliminated. The pot life of certain types is quite short.

Tubes are also very clean and convenient in use, giving easy access to remote corners, which will justify the extra cost to many users.

On the other hand, some adhesives are not suited to tubular packing. This applies to animal and resin glues which require heating, and also to PVA and casein varieties.

Where a large area must be covered evenly and quickly, as for instance in veneering, application by brush is obviously the method to be adopted.



FIG. 3/1. Range of adhesives bought in ironmonger's shop in Ilkley, Yorkshire.

Contact Adhesives. These are very useful for quick setting, and could be used for glue blocks, etc. The adhesive is applied to both surfaces and good adhesion takes place as soon as they are brought together.

Pro Tempore. One special adhesive is worthy of mention as it may be useful to the beginner or experimenter. Its name is COW and it is sold by stationers and artists' supply shops. The virtue of COW gum is that it does not set; and it is in regular use by commercial

ADHESIVES

artists and block makers for sticking proofs and illustrations in position and removing them if necessary at a later date, without damage. In a similar way, a cabinet could be assembled with this adhesive for inspection or for a listening test and then be easily dismantled—and no harm done. Some adhesives give off a strong smell and this is one of them. Fortunately, the smell is also a *pro tem.* characteristic.

With these phew words we will conclude the chapter.

CHAPTER 4

VENEERING

One dictionary definition of veneer is to disguise with artificial attractiveness. This hardly applies to cabinet work, where the practical definition according to Chambers is to overlay or face with another and superior wood. There we have it in a nutshell.

The choice of veneers is very wide and the reader will naturally please himself (or his wife) when buying. Our own experience is that walnut is still the most popular, and the following table shows our average production balance:

Walnut	60%
Mahogany	20%
Whitewood (i.e. unveneered)	10%
Oak	7%
Teak, Maple, etc.	3%

SELF-ADHESIVE VENEERS

The easiest course (and I admit frankly the one I personally should be attempted to adopt) is to complete the cabinet assembly and then apply one of the synthetic self-adhesive veneers which are now available in about 100 patterns. This procedure has three virtues: (1) it is easy to carry out; (2) any rebated joints can be covered, and (3) it precludes the necessity of polishing. I am assuming that the reader is not a budding Chippendale and that we are mainly interested in a cabinet made to listen to rather than a prize-winning piece of furniture.

VENEERED PLYWOOD

If the synthetic touch is ruled out (even in this plastic age) the easiest and quickest course is to buy veneered plywood, or chip-board such as Weyroc, now available in a variety of veneers. Panels could be bought cut to size, but it would be advisable to include a few off-cuts on which to experiment with staining and polishing in due course.

VENEERING PROCESSES

I think the best way to clarify things for the home operator is to describe modern commercial practice and include hints and tips as we go along.

Having bought the veneer, the first thing is to decide on the type of panelling. Fig. 4/1 shows figured walnut arranged in the five most practical ways for speaker cabinets.

VENEERING

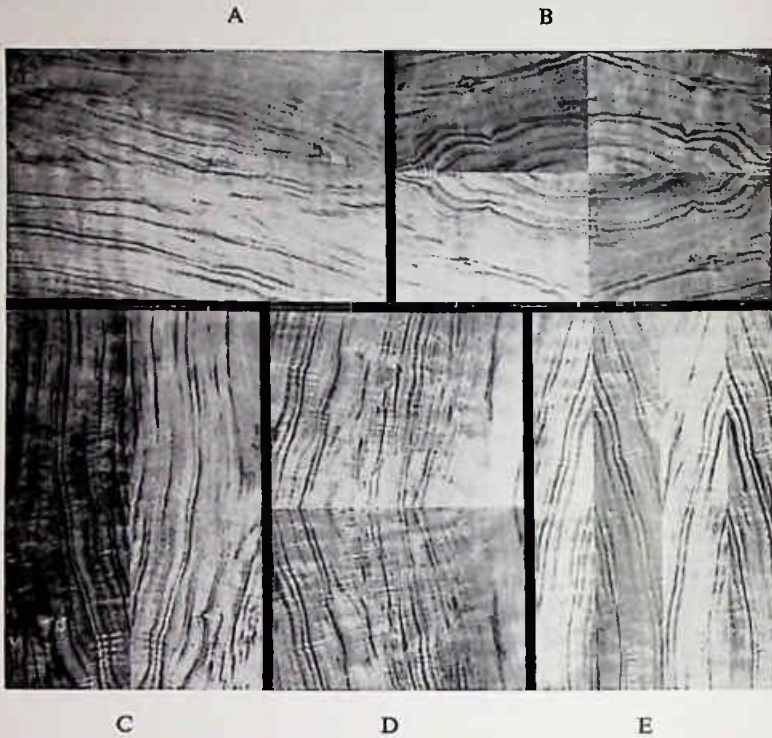

FIG. 4/1. A — *One-piece veneer*;
B — *Quartered*;
C — *Centre joint, lengthways*;
D — *Centre joint, crossways*;
E — *Strip joints*.

The veneer should be cut to a size slightly larger than the panel, to be trimmed off with a sharp chisel after laying and setting. A straightedge and a Stanley knife are useful for cutting, and the joints (if any) should be held together by adhesive tape. In Fig. 4/2 we see a machine which is, to my mind, one of the most fascinating in our own cabinet shop. The veneers, having been cut to size on a guillotine, are joined by sliding under the rollers of the machine, when a fine strip of adhesive tape holds them together. This tape is automatically removed during the sanding process, leaving an almost invisible joint with maximum economy in the use of veneers by eliminating waste.



FIG. 4/2. *Veneer jointing machine.*



FIG. 4/3. *Machine for spreading cold glue by rollers.*

VENEERING

The cold adhesive is applied to panels by rollers as shown in Fig. 4/3, a resin-bonded glue with hardener being used here. The veneer is then laid on and the panels are inserted in the large press photographed in Fig. 4/4, which appears to be of a musical origin. Hydraulic pressure is applied at 45 lb. per sq.in. with a platen temperature of 170°F which sets the glue. The timing bell is set for five minutes and when it rings, a button is pressed to open the platens. The panels are then ready for use. (With such a short setting time, tea breaks are easily avoided.)

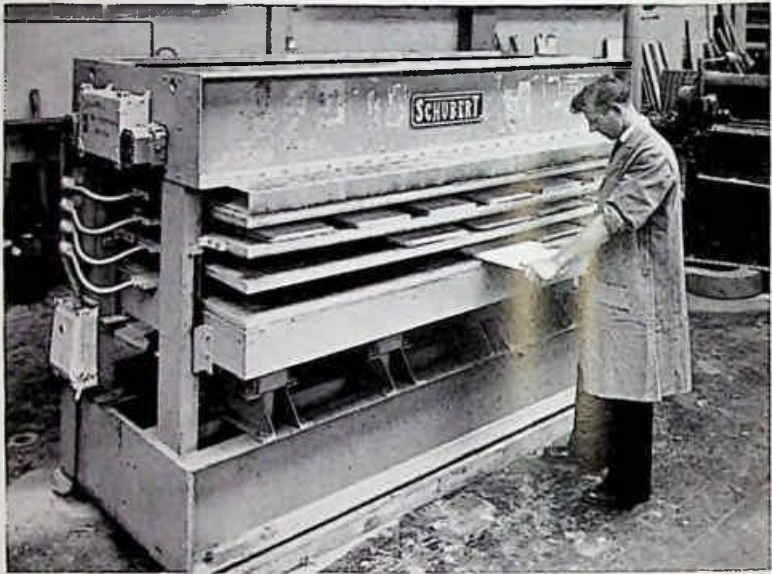

FIG. 4/4. *Automatic veneer press for use with thermo-setting adhesives, with control of pressure, temperature and time.*

HAND VENEERING

Before the introduction of PVA adhesives, hand veneering was usually done with animal glue which was applied hot to the plywood. The procedure was exactly the same as for PVA adhesive—described here—but due to the rapid gelling of animal glue a hot iron had to be used to soften the glue, followed quickly by the squeezing down process. The setting time with PVA is longer and it is, therefore, more convenient to work with when fixing veneers.

A good, firm, bench or table is the first essential piece of equipment, because considerable pressure must be applied during the process, and a card table would merit a call of "no bid".

An important rule is that the grain of the veneer should be laid at right angles to the grain of the plywood as illustrated in Fig. 4/6 under the sub-heading of *Bending*.

The procedure is as follows:

1. Coat the plywood with a PVA adhesive, spreading evenly but not too thickly with a brush.
2. Dampen the veneer on both sides with a wet rag or sponge and lay it on the plywood.
3. With a veneering hammer or some improvised straightedged tool, squeeze out as much adhesive as possible, working from the centre of the panel outwards. It is hardly worth while buying a veneering hammer for an isolated operation. The straight, narrow end of a 6" steel set-square does the squeezing out job quite well with adequate muscular application.
4. Lay the panel face downwards on a newspaper on a flat, hard surface, with plenty of weight on top. After 15-20 minutes the adhesive will be set and the panel is ready for use.
5. Any small blisters can be removed by cutting a slit along the grain of the veneer, applying adhesive underneath and squeezing with the veneering hammer or its substitute.

Finally, if you attain great skill at this and similar craftsmanship, it is no use trying to join the cabinet makers' union, as the qualification is five years' apprenticeship.

Edge Veneering. Where a plywood edge is exposed to view, it is necessary to veneer it to produce a nicely finished job. In the early days, we used to get away with a coating of paint; the cabinet in Fig. 2/6 had the speaker opening rounded off by a special cutter in the router, and this was finished off with paint to match the colour of the cabinet.

Today we do all edge veneering by hand. The strips of veneer are cut slightly wider than the edge to be covered, with the grain running crosswise. The PVA adhesive is applied to the plywood, the veneer is laid on and surplus glue is squeezed out by pressure applied with a smooth, rounded piece of hardwood. After setting, the edges are trimmed with a sharp chisel. The handyman should have no difficulty in performing this operation at home after a little practice on an odd piece of plywood held in a vice. The edge to be covered must of course be flat and clean, and well sandpapered.

Where a large number of panels need this edge treatment, thermo-setting devices can be employed. Fig. 4/5 shows an interesting technique used by Wilkinsons (Bradford) Ltd. Low voltage heating is applied through metal strips to the resin glue and powder hardener (mixed application) which is supplied by Leicester, Lovell & Co. Ltd. of Southampton, who incidentally make the Casco Contact adhesive shown in Fig. 3/1.

VENEERING

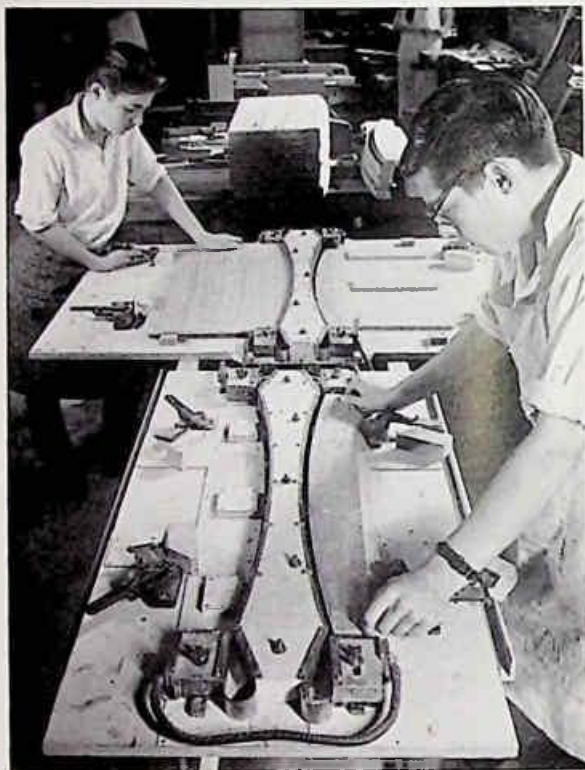

FIG. 4/5. *Edge veneering of panels by low voltage heating.*
Setting time three minutes.

Bending. If thin plywood is veneered on one side only, there is a slight tendency for the panel to bend inwards; this can be counter-balanced by veneering the other side with the cheapest type of veneer which may be available. The normal practice is to veneer across the grain as indicated in Fig. 4/6.

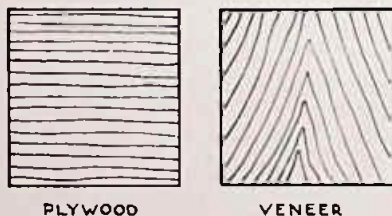

FIG. 4/6. *Direction of grain.*

It is obviously most important that any counter-veneering must also be done across the grain, otherwise bending would be encouraged instead of thwarted. The tendency to bend with solid wood panels is infinitely greater than with plywood, and reverse veneering is usually essential.

Any bending or warping depends on the size and thickness of a panel and how rigidly it is held at the edges and by cross battens.

With the type of loudspeaker cabinets in which we are interested in these pages, plywood $\frac{3}{8}$ " or more in thickness is used, with very rigid construction and edge support, and the risk of panel bending is virtually non-existent. Reverse side veneering can therefore be safely ignored.

Storage. Veneer should be kept at an even temperature in a cool, dark place in an atmosphere which is not too dry. The best place at home would be the cellar (if there is one). The next best for prolonged storage would be an attic, boxroom or unused bedroom, with the veneer protected from strong light, or there may even be some spare accommodation in the pantry. In short, for good health give the veneer the most uncomfortable room in the house.

CHAPTER 5

MACHINES

Although this is a handbook mainly intended for the home constructor—which means that machinery cannot be installed and used—I think the reader will be interested in illustrations and brief descriptions of a few items of woodworking equipment, most of which is designed to speed up production and ensure maximum accuracy.



FIG. 5/1. *General view of machine shop and cabinet assembly plant completed in Idle, Bradford, in 1960.*

The first photograph shows our own woodworking department and gives some idea of the range of equipment necessary for efficient production of comparatively small cabinets.

Next we show in Fig. 5/2 a circular saw fitted with two blades which are adjustable in distance apart so that panels come out with both edges trimmed to the required width.

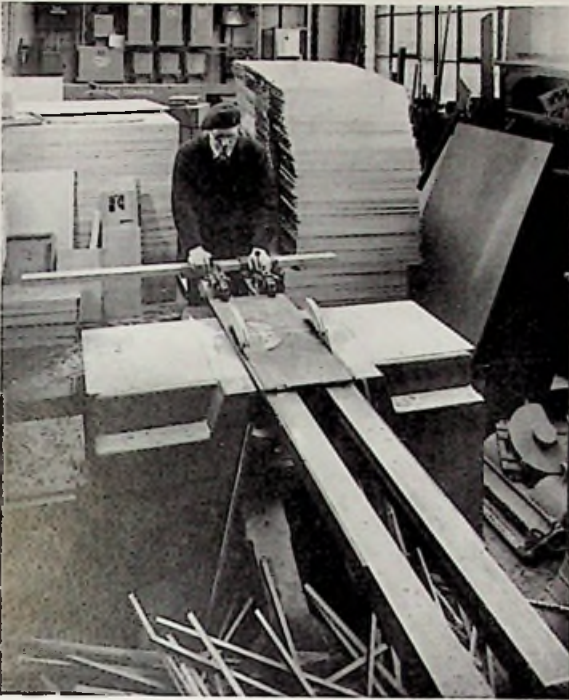

FIG. 5/2. *Adjustable, twin-bladed circular saw.*

SANDING

Once cut to size, the veneered panels can be fed into the automatic sander of Fig. 5/3 which is fitted with rollers set to suit the thickness of the plywood.

Whereas our total cabinet staff can be counted on the fingers and toes of one pair of hands and one pair of feet, to count the number on the pay-roll of Wilkinsons (Bradford) Ltd., who have made many cabinets for us from time to time, you would need six or seven centipedes. Mr. Wilkinson kindly agreed to let us send a photographer to take some pictures of their equipment, three of which are used in this chapter, one in Chapter 4 and two in Chapter 7.

We are using the Wilkinson version of the belt sander (Fig. 5/4), one of the most useful machines in any cabinet shop, because it shows the fine sanding of a cabinet surface *after* filling and spraying with Polyester finishing material. This proves how very hard the new Polyester finish actually is; similar treatment to a cellulose lacquer spray would simply remove it completely.

MACHINES

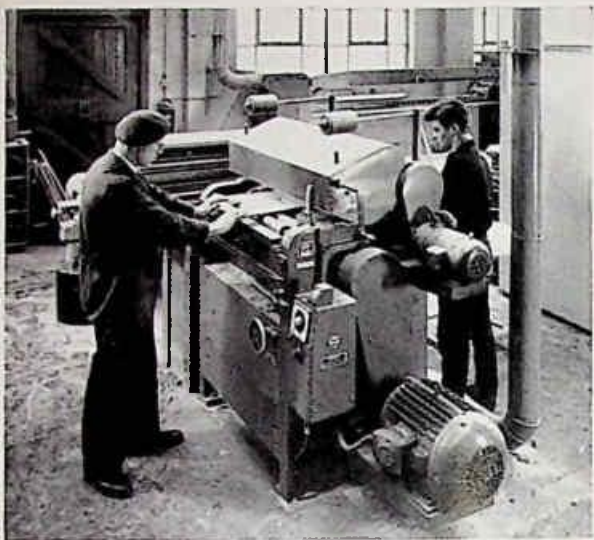

FIG. 5/3. *Automatic sander with adjustable rollers.*

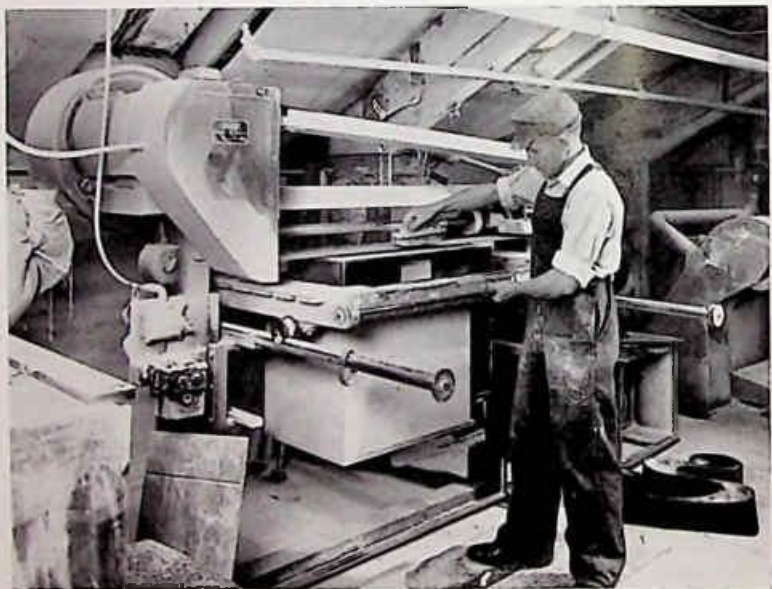

FIG. 5/4. *Sanding Polyester-sprayed cabinets before burnishing.*

To complete the cycle of sanding we have the disc sander, which is useful for removing rough edges from small cabinets, as shown in Fig. 5/5.



FIG. 5/5. *Disc sander.*

BENDING

One of the most useful qualities of plywood is that it can be bent in different ways, one of which is described in Chapter 6. Once reset, the plywood retains its new shape very well. In Fig. 5/6 we see a large machine used by Wilkinsons for the rapid shaping of panels.

ASSEMBLY

When machining and rebating have been completed, there are various ways of assembling the panels into cabinet form with suitable adhesives.

Hand methods include pinning and clamping, but in factories some form of jig assembly is now the order of the day. We use the hydraulic system of Fig. 5/7 with a cold-setting PVA emulsion. Wilkinsons use pneumatic pressure with electric heating to set the resin adhesive, Fig. 5/8.

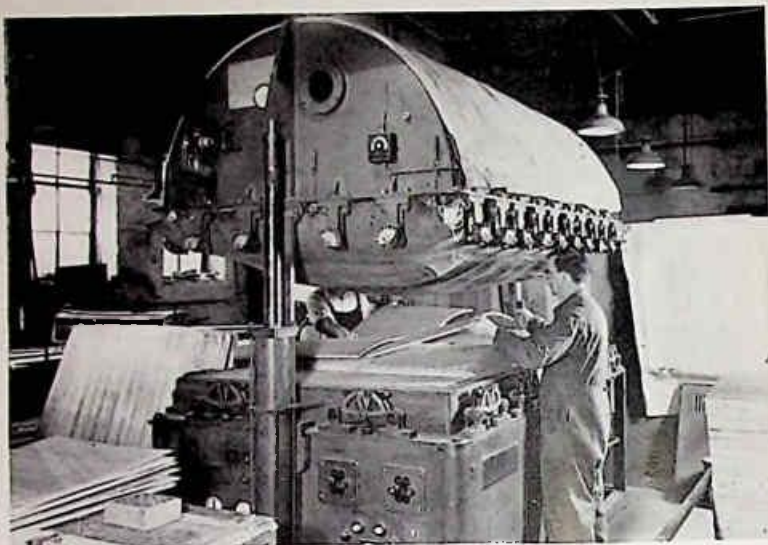

FIG. 5/6. *Panel-shaping machine using vacuum and compressed air, with heat applied to both sides of panel.*



FIG. 5/7. *Hydraulic assembly jig used with cold PVA adhesive. Setting time ten minutes.*

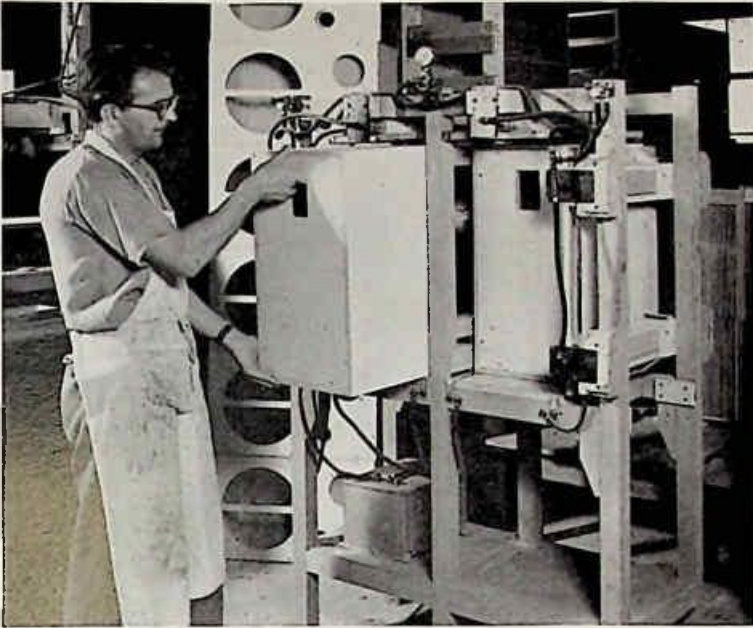

FIG. 5/8. Assembly jig using pneumatic clamps, and low voltage heating to cure the resin adhesive in the joints. Setting time with resin glue and powder hardener (mixed application) is only three minutes.

There are, of course, scores of other woodworking machines such as planers, routers, spindle moulders, etc., which can be seen in almost any cabinet- or furniture-making factory.

For this chapter we have merely selected a few which have some special significance and may help to steer the "Do-it-yourself" hero along the thorny road to success.

CHAPTER 6

ASSEMBLY

In tackling the art or craft of cabinet assembly, we propose to deal with some of the basic methods and leave the reader free to adopt the ideas which seem to suit his own skill and requirements.

The only things that are important in a loudspeaker cabinet are size, shape, rigidity and internal treatment by absorbents. The method of assembly and external decorations make no difference to results so long as these fundamentals are reasonably observed.

This approach, together with the advice given in Chapters 9 and 10 on Resonance and Absorbents, helps to simplify the constructional details of the designs outlined in Chapter 12 and thus keep down the size and cost of the book, instead of wasting time and space in specifying details like glue blocks and giving elaborate cutting lists.

REBATED JOINTS

Once the panels for a cabinet have been cut to size, the main question is the method of corner jointing. There are many ways of doing this. Three of the most practical are illustrated in Fig. 6/1, where at A we have the old original rebate which leaves two layers of plywood showing; at B is the method used in our own factory and at C we show the system adopted by Wilkinsons (Bradford) Ltd. Jig assembly is applied to both B and C as illustrated in the previous chapter.

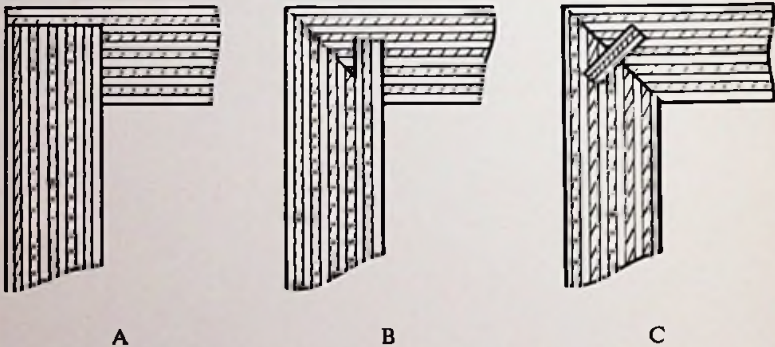

FIG. 6/1. *Corner joints in plywood. (Veneer not shown.)*

- A — *Flat rebate;*
- B — *Tongued and grooved mitre;*
- C — *Keyed mitre.*

It is obvious that for B and C the panel ends must be accurately shaped in a spindle moulder or similar machine, and so the idea is useless for the home constructor, which leaves us with rebate A. This is probably the most feasible hand-made joint. Layers of ply are removed to a width of the panel to be fitted, leaving a lip about $\frac{1}{8}$ " thick—usually two layers of ply. The easiest way to work is to scribe the width with a marking gauge (No. 14 in Fig. 11/1), fix a back rail along it with a couple of panel pins and then saw through the plywood with a tenon saw to the required depth. The rail guides the saw and is easily removed, and the strips of plywood are removed with a chisel.

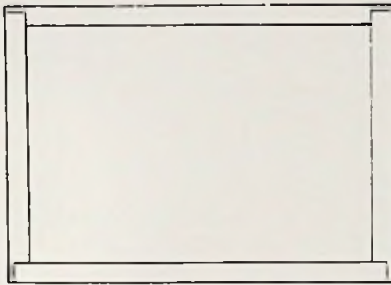

FIG. 6/2.
*Method of rebating panels
in the four sides of a ply-
wood cabinet.*

The joints are then secured with a hot glue or a modern PVA cold adhesive, with a few panel pins and some interior glue blocks to hold things together. These pins should be knocked in with a hammer and then a fine punch, the small hole being filled with stopper. Unfortunately, the pin holes tend to show up after polishing and the only way to avoid this is to use plain plywood and veneer the cabinet after assembly, either with wood veneer and glue or with a self-adhesive plastic variety. This type of post-assembly veneering also covers the plywood edges of the rebates.

GLUE BLOCKS

These are useful fittings. They hold a cabinet together and often improve rigidity. Any softwood will do, and they may be $\frac{1}{2}$ " to 1" square or cut to a triangular shape. They are easily fixed by coating two sides with glue and sliding them sideways once or twice on insertion to squeeze out surplus adhesive and ensure quick setting. Fig. 6/3 shows typical use of glue blocks in a three-speaker enclosure, along with battens securely fixed to side panels to subdue resonance.

FRONT PANEL

Having assembled the walls of the cabinet, the front can be fitted by rebating on all sides as shown in Fig. 6/4.

ASSEMBLY

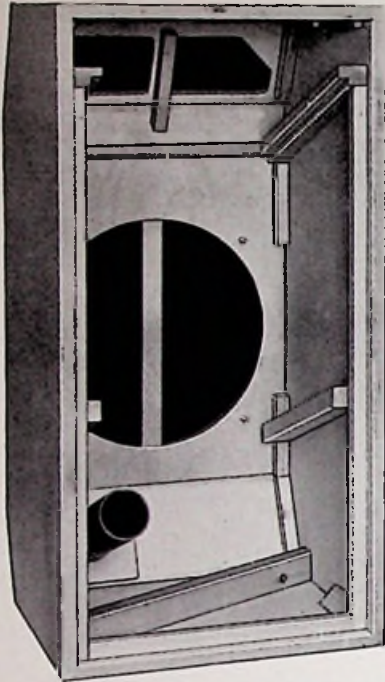

FIG. 6/3.
*Interior view of cabinet
showing glue blocks and
battens.*

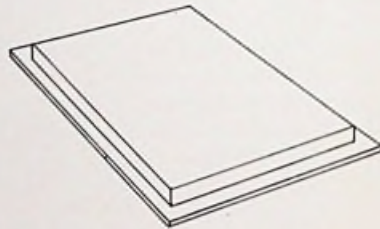

FIG. 6/4.
Rebated front panel.

Speaker openings and tuning ports will have been cut out, and the panel is glued and placed in position and held down by weights until set. It is not a bad idea to put the cabinet face down on a flat surface, place a board on top and sit on it for a few minutes. Panel pins will not be necessary, but a few glue blocks may be advisable.

CABINET BACK

The easiest way to fit the back is to screw 1" \times 1" rails to the inside of the cabinet at a distance to suit the thickness of the back panel, which is then screwed into position.

Many designs today call for an air-tight fit. A layer of felt or soft cloth glued to the back rails helps to ensure this.

It should be remembered that the cabinet back is usually the largest panel in the structure and is therefore the most resonant. Sand filling is described in Chapter 9 and tile treatment is illustrated in Fig. 1/3.

In a shallow or slim-line cabinet, a couple of dowels firmly anchoring the back to the front panel are cheap and effective.

FRAME WORK

The front of the cabinet—unless nicely veneered—will need a hardwood frame in which a decorative mesh can be fitted. The easiest way to fix the frame is by gluing and pinning but the pin holes may be visible.

A better method is to screw into the frame from the inside of the cabinet through the front panel. The fret material is then glued on and bordered as described in Chapter 8.

Another method is to assemble the sides of the cabinet and fix them to a solid frame at the front. The mesh is then fixed to the front panel or baffle *before* insertion into the cabinet, thus overcoming the necessity of edge-of-mesh decoration.

HIDDEN JOINTS

One way of avoiding rebated joints is to use larger side panels to which solid wood rails are glued and screwed. The front, top and bottom of the cabinet are then fixed as shown in Fig. 6/5.

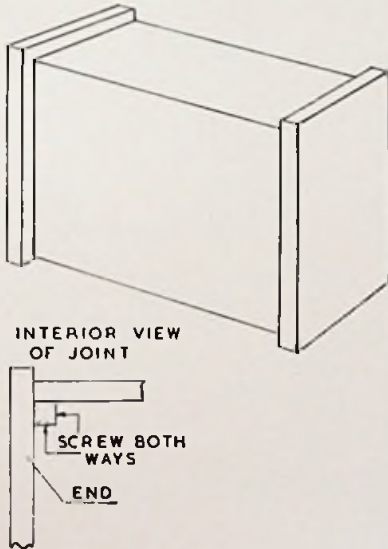

FIG. 6/5.
*Cabinet with extended sides to
avoid rebated joints.*

ASSEMBLY

The whole of the front, top and bottom of the cabinet is then covered with fret material. The cabinet sides should be in plywood $\frac{1}{2}$ " or more thick, and the edges should be veneered, but polishing is reduced to a minimum.

Another method which is practical with cabinets of reasonable size and weight is to bend the veneered plywood and rebate the two ends as per Fig. 6/6.

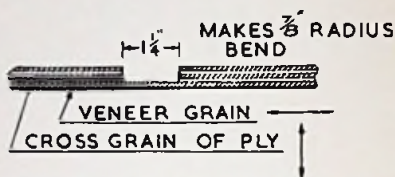
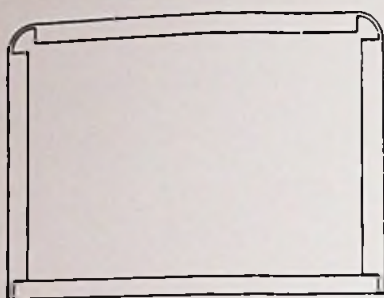

FIG. 6/6.

Cabinet assembly arranged to avoid pin holes and visible plywood edges.

The layers of ply are removed by a chisel after sawing down to the last layer plus veneer. The grain of this last layer *must* run across the panel, with the veneer running lengthways. Apply a little hot water or steam and the bend to a right angle is easily made. The width of the strip of ply removed determines the radius of the bend, and the insertion of an accurately shaped and rebated front panel squares up the assembly.

CHAPTER 7

POLISHING

The most important part of the process of polishing is the preparation of the surface. Trying to polish rough veneer or hardwood is rather like trying to play a piano without a keyboard. The secret of achieving a smooth surface is, of course, sanding and the final touch is applied by using a fine grade of glasspaper, say No. 1, which for hand use would be wrapped round a cork rubber, illustrated in Fig. 11/1.

ELECTRIC SANDER

To save time and elbow grease, an electric orbital sander is a good investment but it sets you back nearly £15. Two of these are being used in Fig. 7/1 in the final stage of cabinet making prior to passing on to our polishing department. Incidentally, a portable electric sander is also extremely useful in the home after paint stripping during redecorating activities, but can only be used on flat surfaces.



FIG. 7/1. *Final sanding of cabinets preparatory to polishing.*

POLISHING

It is assumed that any pin holes will have been filled with plastic stopping (now available in tubes or tins) before the final sanding is undertaken.

STAINING

Although light oak, figured walnut and bird's-eye maple veneers look very attractive when nicely polished in their natural colours, some staining or dyeing is usually necessary. To test the supply situation I paid another visit to Morton's in Ilkley where I purchased the adhesives already described in Chapter 3, and they offered me an assortment of twelve colours in *Colron* wood dye made by Ronuk Ltd., so there is no problem here. The main point is to test the colour on a spare piece of wood or veneer, as it is impossible to foretell what the final shade will be. Full instructions for use are given by the makers.

A fairly wide brush should be used for staining panels, starting at one side and working along the grain as quickly as possible. A small brush will be required for mouldings or frame work, with a pencil brush for touching up.

It is important to begin with a colour rather too light than too dark, as the subsequent treatment tends to darken the shade, and two or three practice panels may be necessary for the beginner to ensure accurate results, and to test the filling, sealing and polishing processes which complete the job.

FILLING

This is usually necessary and facilitates the achievement of a smooth, final finish, although some veneers and timbers such as oak and teak look better with the grain showing and without being too sleek and shiny.

The best plan is to buy a proprietary filler (coloured to suit the job if the shade is dark) and apply it across the grain with a canvas or rag according to instructions. Any surplus filler must be rubbed off and the surface then left to dry for about twelve hours. Sealing with two coats of lacquer or shellac and a final smoothing over with glasspaper leaves the panel ready for the final polishing process.

COMBINED OPERATION

Before dealing with the polishing problem, it may be useful to point out that the staining and filling can be done in one operation, and Fig. 7/2 shows two of our polishers enjoying themselves in just this way.

The reader may succeed in buying a combined stainer/filler of the correct shade, or alternatively he could mix the ingredients himself before application and make tests on sample panels. It is hardly possible to give instructions here which would ensure successful results.

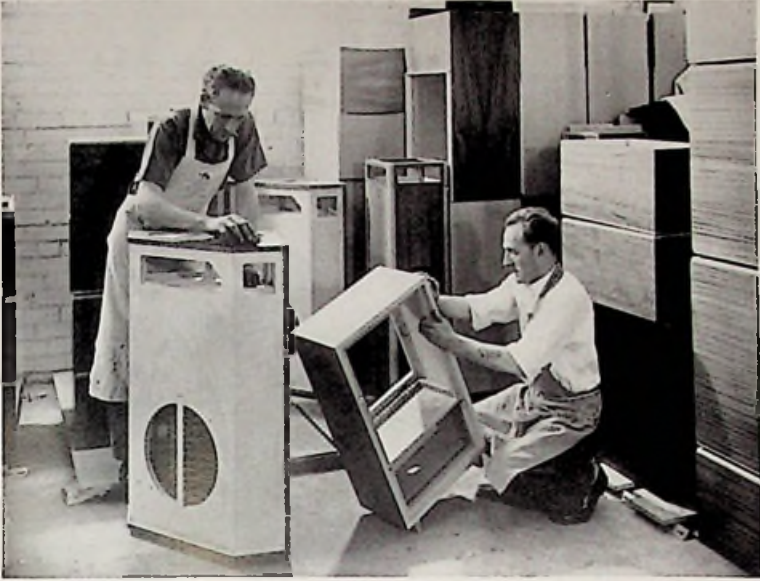

FIG. 7/2. *Staining and filling cabinet surfaces in one operation.*

FRENCH POLISHING

In spite of all the progress that has been made in spraying and burnishing techniques during the last 25-30 years, I still maintain that there is no finish to compare with first-class french polishing, which is ruled out today by the factors of time and skill.

Although I would not advise amateurs to go in for this method of polishing, full instructions are given by C. H. Hayward in the book mentioned in our Bibliography, and the necessary materials can still be purchased.

French polish is made by mixing shellac with methylated spirits and is produced in four shades: white, orange, button and garnet. In our early cabinet-making days we normally used button polish and I was always impressed by the skill with which the polisher could reduce a bright finish to any degree of "matt" by spiriting off, the interesting point being that it was impossible to end up with a good matt surface without having first produced an excellent bright finish. In other words, the dull finish was the most expensive.

WAX POLISHING

Having, during the last two or three years, gone over entirely to wax finishing in our own polishing department, this is the finish I recommend to the amateur. The beauty of wax is that it is neither too

POLISHING

bright nor too dull and slight scratches or even rings from cups and saucers or beer tankards can be removed by the vigorous housewife with a fresh application of wax polish (which is available by the ton) and plenty of elbow grease.

Our method is to spray two coats of cellulose lacquer on to the prepared cabinet, sand by hand and apply the wax polish also by hand, with a few minutes of vigorous rubbing with a soft cloth. We did actually install an electric rotary burnishing machine for this final operation, but we never use it as we prefer the hand finish.

Working at home, shellac or button polish would be used as the sealer with pure bees wax and a little turpentine as the polishing medium.

With natural oak finish, without staining or filling, it is not necessary to use a sealer.

OILED TEAK

The best treatment for teak is undoubtedly oil polishing, which incidentally is the simplest to put in hand. No filler is required and raw linseed oil is applied with brush or rag. Three coats would be sufficient, with 12 hours between coats, although for a really durable surface Mr. Hayward recommends daily application of oil with vigorous rubbing over a period of five or six weeks!

After becoming almost obsolete, oil polishing is now being revived and is used even on walnut veneers, especially in America where the dull brown finish seems to be very popular.

POLYESTER FINISH

Probably the biggest jump from french polish, wax and oil is the polyester finish, developed since 1956 by I.C.I. and widely used today on TV cabinets. Although quite out of reach of the home operator (the special spraying and burnishing equipment costs £2,000-£3,000) I thought a brief description might interest some readers.

Polyester is not a cheap finish and is only a practical proposition where large numbers of identical cabinets are in production. A very hard, smooth and glossy surface is obtained and is practically indestructible. (We have already shown in Fig. 5/4 that it will withstand the rigours of belt sanding.) Actually, a type of material originally suitable only in the plastics industry has been modified for use as a surface coating.

The process of polyester finishing is very exacting, with carefully controlled mixture of accelerator with finishing material, drying time between coats, room temperature (65°F minimum) and so on. The photographs of Figs. 7/3 and 7/4 were taken at Wilkinsons (Bradford) Ltd., and show the spraying and final burnishing processes.



FIG. 7/3. Polyester spraying with ducts to supply exact mixture of accelerator and finishing material.

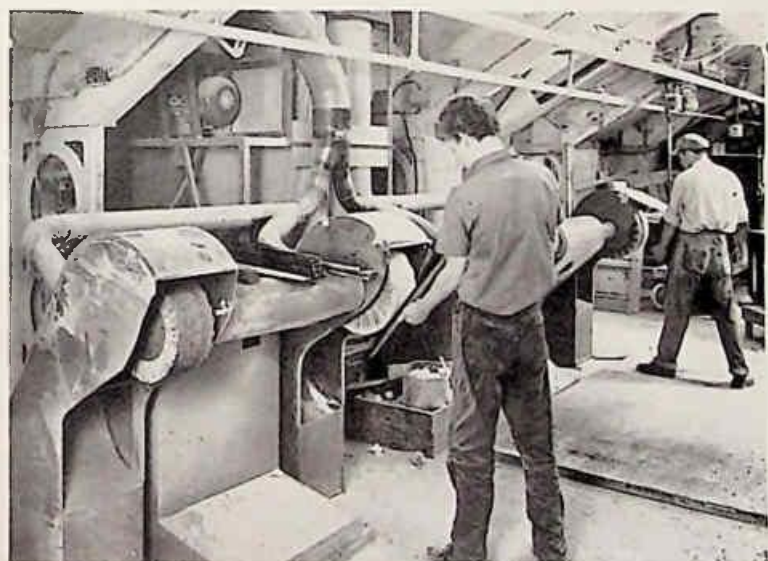

FIG. 7/4. Final burnishing (after belt sanding) with mops rotating at 1,500 rpm.

POLISHING

REFINISHING

If you are dissatisfied with a job, the polish can easily be removed with a paint stripper and a scraper. Modern strippers are very powerful and will even remove polyester finishes.

As a dark stain permeates veneer, stripping may not be effective for changing to a lighter shade.

CHAPTER 8

MESH

After a cabinet is assembled and polished, it is necessary to fit some sort of decorative material to cover the speaker and/or vent openings. Almost anything can be used here, provided it is well perforated or has an open weave to allow the sound waves to pass through.

When covering a large area, the first precaution is to stain or paint the front of the cabinet to match, within reason, the colour of the LS cone so that it does not show through the mesh. If the cone is dark grey or black, the surrounding surface should be blackened. A vent opening usually looks black because of the absence of light inside the cabinet. With a cone which is white or very light in colour, it may be necessary to enclose the speaker unit in a black cotton dust bag before mounting, or to glue a piece of black material across the speaker opening or over the entire front panel.

The two most widely used fret materials today are Expanded Aluminium and Tygan. As these are both distributed through wholesalers and radio dealers, we can usefully examine the best methods of application.

EXPANDED ALUMINIUM

This is produced in a variety of designs and finishes, and also in different thicknesses. I would recommend anodised bronze or gold finish in 20 gauge aluminium as being durable, attractive in appearance and not easily bent out of shape. The cost retail, cut to size, runs at about 6s. 9d. per sq.ft. with a possible extra charge for waste.

When ordering special sizes, always state clearly which is the horizontal dimension as the mesh should be mounted the right way up.

In order to avoid possible buzzing and rattling, a layer of soft black cloth should be glued to the plywood to cover the entire surface on which the mesh will rest. (This, incidentally, may avoid the necessity of staining the plywood.) A cheap black melton, about 10 oz. or 12 oz. to the yard, is suitable and is thin enough to let the sound through and soft enough to avoid audible vibrations of mesh. Almost any sort of glue will stick cloth to wood. Another point is that a layer of cloth fitted tightly over a speaker opening helps to damp excessive cone movement at bass resonance, and this is an advantage with open baffle mounting.

The mesh is easily fixed in place by strong staples or small screws and washers, inserted around the edges 6" or 8" apart. A strip of

MESH



FIG. 8/1.

Expanded aluminium in a plain design.

wood or beading to cover these fixing devices completes the job. Adhesive, plastic strip is also available.

TYGAN

This is a synthetic material specially made for loudspeaker covering by Fothergill & Harvey Ltd., Littleborough, Lancashire. (There are, of course, other makes of fret materials of attractive design and appearance.)

Two of the main distributors of Tygan (among others) are:

Norman Rose (Electrical) Ltd.,
47/53 Hampstead Road,
London N.W.1, and

A. C. Farnell Ltd.,
North Court,
Vicar Lane,
Leeds 2, Yorkshire.

The retail price of the material is 49s. 6d. per yard 54" wide and it is freely distributed through radio dealers. Messrs. Norman Rose carry 15 different patterns in stock and Messrs. Farnell offer the range illustrated in Fig. 8/2. (The colours can't be shown here.)

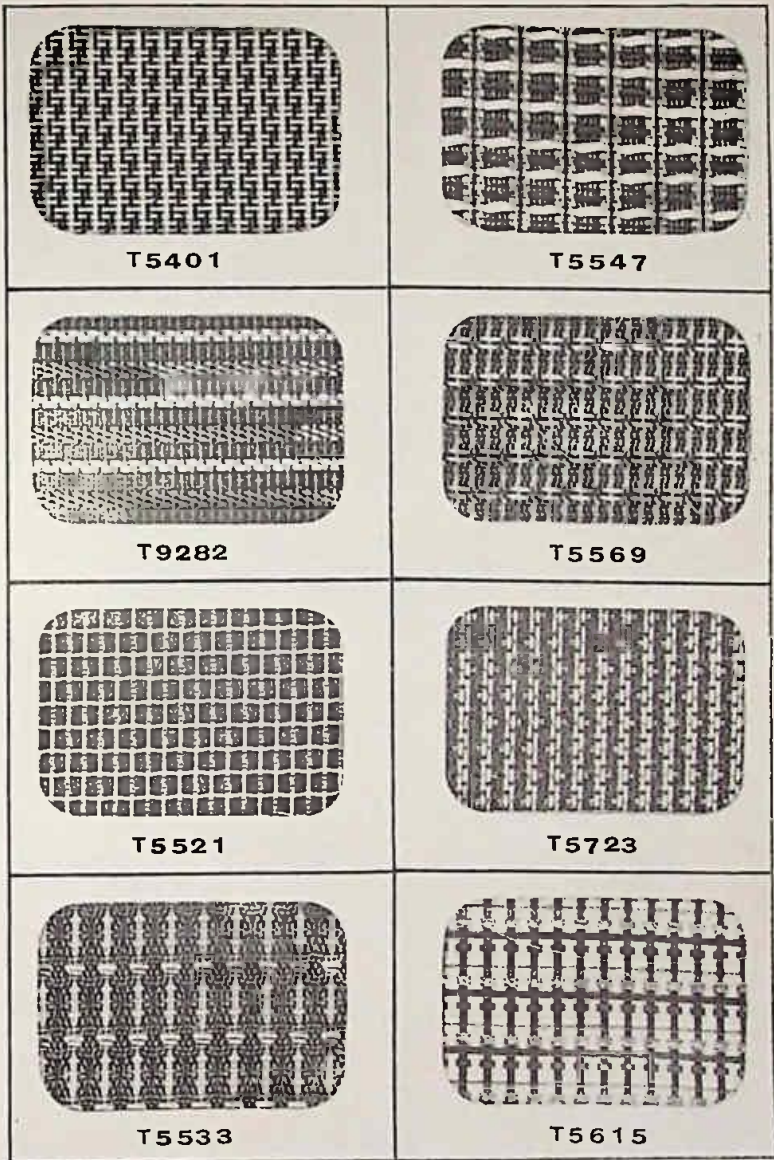

FIG. 8/2. Stock range of designs in Tygan.

MESH

The Tygan should be cut to size and glued in position by using a colourless adhesive. (We find Titebond sets at about the right speed. This is sold in tubes through Halford's cycle shops.) The adhesive must be applied only around the edges, say, to a distance of 2" or 3" according to the size involved. This makes it possible to apply the HEAT TREATMENT, which is the secret of ending up with a flat, taut surface which will not sag. You hold an electric radiator about 6" away from the mesh for about five seconds, when the heat begins to contract the fibre. Remove the radiator *immediately* a slight movement is seen in the Tygan, otherwise excessive contraction will be induced. In half a minute, the material can be made to shrink 25% so do not warm up to the job unduly, unless you enjoy buying and refitting the stuff as a pastime.



FIG. 8/3. Removing electric radiator after heat treatment of Tygan. At least 12 hours should be allowed for adhesive to set before this shrinkage is applied.

To complete the decorations, the edges may be concealed by fitting a border of corded silk which can be bought by the yard, in assorted colours, in stores and furniture shops. The cord is easily and permanently fixed with a transparent tubular glue such as Bostik No. 1 clear or Uhu, which set quickly.

In tropical countries, it is advisable not to expose these synthetic fabrics to brilliant sunshine.

CHAPTER 9

RESONANCE

Resonance in loudspeaker cabinets can in many ways be compared to alcohol. In some cases it is useful in small doses; some people like it more than others, and too much is harmful and intoxicating. A really fit man in training is better without any at all, and we could say that a perfect loudspeaker would have no resonance but might sound a bit cold.

Room resonance is rather similar but more generally desirable in reasonable doses, because listening to music in a dead room is a dead loss.

Unfortunately, with loudspeaker cabinets we have to make use of enclosure resonance as size is reduced, otherwise we lose bass response, and that in a nutshell explains why properly designed large enclosures sound better than small ones, and always will. But room limitations and stereo make small enclosures very popular today and quite good results are possible with careful design and a judicious balance between treble and bass output.

Types of resonance. There are two main types of cabinet resonance. One is due to enclosure volume and becomes less and less harmful as size is increased. The other is due to panel resonance and becomes much more pronounced as size is increased. Both varieties show up more as volume level is increased.

We deal with enclosure resonance in the next chapter under the heading of Absorbents, so the remainder of this chapter is devoted to panel resonance, which is much more serious with reflex and total enclosures than with open back cabinets.

PANEL RESONANCE

There is really not much new to be said on this question, but the main considerations are worth repeating in a handbook of this nature.

The objections to panel and structural resonance are: (1) reproduction is coloured; (2) energy is absorbed; (3) transients are blurred by hangover. Getting rid of such resonances results in cleaner sound, better bass and brighter top. I often think it is rather like letting some fresh air into a stuffy room.

Size. As panel area is increased, the resonance goes up rapidly and greater rigidity becomes necessary.

RESONANCE

For a panel $12'' \times 6''$, plywood $\frac{3}{8}''$ thick is satisfactory. At a square foot, $\frac{1}{2}''$ ply is advisable, and at 2 sq.ft. upwards we have to think in terms of $\frac{5}{8}''$ ply, hardboard and plywood glued together, sand filling and even bricks and mortar or concrete.

Vibration Test. In the 5th Edition of *Loudspeakers* we illustrated a number of tests made with panels 2 ft. square; these are reproduced in Figs. 9/1 and 9/2. A steel ball $\frac{3}{4}''$ in diameter was allowed to strike a glancing blow at the centre of the panel. The resulting noise was photographed on the 'scope, and the pictures show the intensity and duration of the vibrations produced, as well as the harmonic contents of the sound.

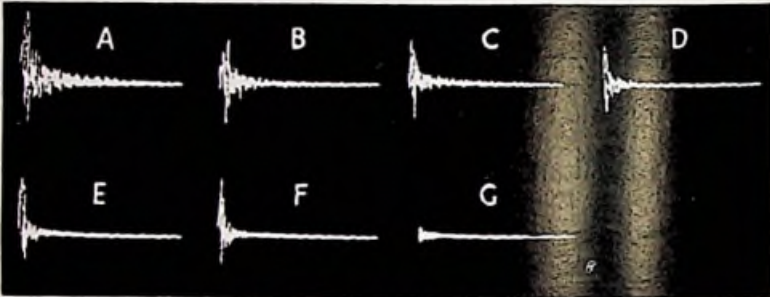

FIG. 9/1. Oscillograms showing vibration produced in $2' \times 2'$ panels by shock test. Time base 150 milliseconds.

The panels tested were as follows, in order of weight—					
					Weight $2' \times 2'$
A	$\frac{3}{8}''$ Plywood	5 lb.
B	$\frac{3}{8}''$ Plywood crossbraced diagonally	6 $\frac{3}{4}$ lb.
	battens	
C	$\frac{3}{8}''$ Plywood lined $\frac{1}{2}''$ Celotex	8 lb.
D	$\frac{1}{2}''$ Weyroc or Chipboard	9 $\frac{1}{2}$ lb.
E	$\frac{3}{8}''$ Plywood lined $\frac{3}{16}''$ Kelseal	10 lb.
F	Sand-filled panel—				
	$\frac{3}{8}''$ ply, $\frac{3}{4}''$ sand, $\frac{3}{8}''$ ply	35 lb.
G	2" thick concrete	94 lb.

As a result of the tests, the following deductions can be made:

1. $\frac{3}{8}''$ Plywood lined $\frac{3}{8}''$ building board is superior to $\frac{1}{2}''$ plywood.
2. Weyroc is very hard and dense and is superior to plywood, but it blunts tools very quickly and requires a frame of solid wood for cabinet work. Veneered Weyroc panels are now obtainable from timber merchants.

3. Kelseal is a sand-loaded compound normally applied very thinly to motor car panels for purposes of damping, and is sold by garages. An application $\frac{3}{16}$ " thick to plywood is a really effective vibration killer, but it takes several days to dry.
4. Cross-bracing is the least effective treatment of those tested, and the use of thicker plywood is not so good as the treatment outlined under C, E and F.
5. Concrete is virtually 100% non-resonant. A similar result is obtained with bricks and mortar, marble, slate, earthenware and like materials. Sand-filling comes next for good results at low cost, especially with large areas.

The three oscillograms of Fig. 9/2 show what happens during the first 5 milliseconds of vibration (.005 sec.).

Note how the Celotex lining destroys the regular harmonics of the plywood vibration and the concrete treats the attack with apparent indifference. In fact, the small wiggles seen at G may be partly due to vibration of the steel ball itself.

Broadly speaking, the density of the material is the best guide; the heavier the better if a single medium is used. But the bonding of two materials such as plywood and building board cuts down resonance with a minimum increase in weight.

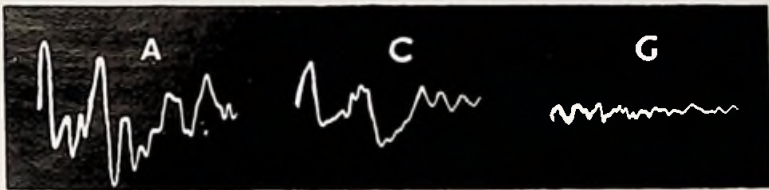

FIG. 9/2. Same as Fig. 9/1 but time base reduced to 5 milliseconds.

- A — $\frac{3}{8}$ " Plywood.
 C — $\frac{3}{8}$ " Plywood lined $\frac{1}{2}$ " Celotex.
 G — 2" Concrete.

Sand filling. As a resonance absorber, this treatment is hard to beat and is fairly easy to apply. The first sand-filled panel I ever saw was at the B.B.C. Research Station at Balham nearly 25 years ago when Mr. Shorter gave me a demonstration of live *versus* recorded voice, the reproduction being via loudspeaker mounted on a large sand-filled baffle. Since then, we have poured tons of dry sand into thousands of panels and baffles and we still do it by hand, in the manner indicated in Fig. 9/3.

For small panels of about 2 sq.ft. two sheets of $\frac{1}{4}$ " plywood are adequate with $\frac{1}{2}$ " sand between them, well packed in by tapping. For large panels it is advisable to use $\frac{1}{2}$ " ply with 1" of sand.

RESONANCE



FIG. 9/3.
*Professional method of
sand filling.*

Dowels. Reference has already been made to the use of securely fixed dowels. Fig. 9/4 shows the application to a cabinet designed in 1952 to fit under a harpsichord for amplification in concert halls.

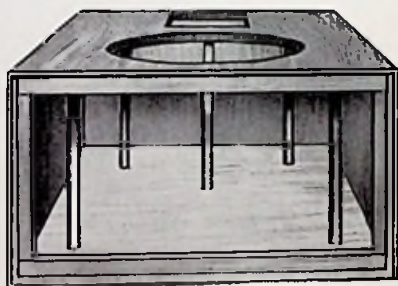

FIG. 9/4.
*End view of reflex cabinet
fitted with dowels to reduce
panel resonance with mini-
mum increase of weight.*

Baffles. Although the sound pressure is less with open baffles than with tuned or total enclosures, the area is bigger and is subject to some direct vibration from the loudspeaker chassis. Any baffle used for full range reproduction must, therefore, be non-resonant and heavy, as outlined under Materials in Chapter 1.

Small baffles used for response above 400 c/s (with crossover network) are quite satisfactory in $\frac{3}{8}$ " plywood.

CHAPTER 10

ABSORBENTS

The popularity of the compact enclosure has resulted in an ever increasing use of internal sound-absorbent materials which have—in short—become a necessary evil. The mere fact that they have to be used proves that there is something fundamentally wrong, which is just another way of saying that large speaker enclosures are better than small ones, but this does not mean that small ones should not be used and “doctored” for optimum results.

Apart from the obvious effect of raising the frequency of cone resonance, the main source of trouble is resonance between reflecting surfaces which occurs when the distance between them is half a wavelength. As cabinet size is reduced these resonances are produced at higher frequencies (and are therefore more objectionable to the ear) and the Q increases, which means that the resonances become stronger and more sharply defined.

They are heard mainly through the cone, which is one reason why it is more difficult to cope with a 12" speaker in a $1\frac{1}{2}$ to 2 cu.ft. enclosure than with a 10" or 8" unit. The cone area of a 12" speaker is about three times as big as the 8" cone, so internal resonances are more clearly heard through it.

Our experiments in lining and/or filling cabinets with absorbents had included the use of soft fibrous material like bonded acetate fibre, soft rubbery sheets of foam plastic, and light, rigid, expanded polystyrene. I was very pleased when our old friend James Moir, a world authority on acoustics, agreed to do some special research into our particular problems and his interesting report now follows.

ABSORBENTS IN LOUDSPEAKER CABINETS

By James Moir, M.I.E.E.

The work described herewith was commenced in order to assess the relative merits of some of the acoustical absorbent materials used to reduce or damp out the acoustic resonances in loudspeaker cabinets. During the course of the work it became obvious that the position of the material was in many instances more important than the material and the project was extended to find the best position for mounting damping material in an enclosure of 1.8 cu.ft. volume, inside dimensions $22\frac{1}{2}'' \times 12\frac{3}{4}'' \times 10\frac{1}{2}''$, tuned to 40 c/s by a tube 8" long and 2" internal diameter.

Cabinet Resonance and Sound Quality

It is usually considered that cabinet resonance detracts from the quality of the reproduced sound largely because it is not present in the signal input to the loudspeaker. Though this is a reasonable assumption, there is considerable evidence that the ordinary public have some preference for the special kind of tone quality that results from the presence of some degree of cabinet resonance. This is not too surprising in that practically all the stringed instruments incorporate an acoustically resonant cavity having the same general resonance characteristics as a speaker cabinet.

It will be noted that all these resonances involve the air in the enclosure and that structural resonances in the woodwork play no part. To this extent the term cabinet resonance is misleading though it is widely used. Resonance may occur in the cabinet structure and can have undesirable consequences but this aspect is not discussed in this report.

Any form of resonance modifies the sound quality in two ways. At the resonant frequency it increases the efficiency of conversion of electrical energy to sound energy and thus a peak appears in the frequency response characteristic. The second effect is more subtle and difficult to assess objectively. A resonant element absorbs energy from the sound wave (or electrical circuit) and radiates it at the resonant frequency and continues to radiate it after the exciting wave has ceased. In other words, it produces "hangovers". Both forms of distortion increase as the "Q" of the resonance increases. (See Appendix I for an explanation of the parameter Q.)

In spite of this, the "distortion" introduced by the peaks and hangovers may be beneficial. Resonances below about 200 c/s provide added bass response though, if this is excessive, the critical ear can detect the difference between true bass and the result of cabinet resonance. The "just detectable" point is hard to define but the little work that has been done on the problem appears to show that in the region of 40-120 c/s the presence of a resonance having a Q greater than 3 is just detectable to the critical ear. In a cabinet intended for the mass market a Q of 6 is probably acceptable. In a bass reflex cabinet one mode of resonance is relied upon to reverse the phase of the radiation from the rear of the speaker unit and thus this particular resonance cannot be entirely eliminated.

Origin of Cabinet Resonance

In any rectangular enclosure there are three independent series of resonances, the fundamental frequency of each series occurring at the frequency at which either the length, width or depth of the cabinet is one half wavelength. There are other series of resonances corresponding to combinations of the length, width and depth dimensions but in general these do not appear to be serious. With internal dimensions of 22.5" x 12.75" x 10.5" the primary resonance for

length, width and depth should occur at frequencies of 293, 516 and 628 c/s.

The presence of all these resonances was confirmed, the calculated and measured values of frequency and the Q at each frequency being shown in the following table.

TABLE 1
Basic Resonance Frequencies of the 1.8 cu.ft. Cabinet

<i>Mode</i>	<i>Calculated</i>	<i>Measured</i>	<i>Q</i>
Length 22½"	293 c/s	300 c/s	30
Width 12¾"	516 c/s	510 c/s	38
Depth 10½"	628 c/s	620 c/s	52
Reflex	33 c/s	40 c/s	1.5
Duct	740 c/s	740 c/s	40

Note how the Q increases as dimensions are reduced.

One other major resonance exists, that due to the acoustic stiffness of the volume of air in the enclosure and the mass of air in the port. This is the basic resonance necessary for the operation of a bass reflex cabinet and thus it cannot be eliminated though its amplitude should be controlled.

Performance of Absorbing Materials

The original requirement was for a set of figures comparing the performance of ¾" expanded polystyrene, ¼" foam plastic and 1" bonded acetate fibre in damping cabinet resonance. For these comparisons, a 3" deep layer of each material was put into the same position at the end of the cabinet and the acoustic Q measured. The values are given in Table 2 and it will be seen that the acetate fibre is the most effective material (the lowest Q), closely followed by polyurethane foam, with expanded polystyrene some way behind. For most of the subsequent investigation into the optimum mounting position, the acetate fibre and polyurethane foam were employed.

TABLE 2
Relative Efficiency of Absorbing Materials at 300 c/s

<i>Material</i>	<i>Enclosure Q</i>
Acetate Fibre	14
Polyurethane foam	17
Expanded Polystyrene	22

Note 1: High absorption is indicated by a low Q.

Note 2: Materials assembled to give a depth of 3" at one end of cabinet for tests.

Mounting Position

The amplitude of any or all of the resonances can be controlled by the addition of acoustic damping material to the enclosure. Technically the actual material employed is not very significant for substantially the same final result can be obtained from all materials,

ABSORBENTS

but there is always the economic problem of achieving the desired damping at the minimum cost. This is affected not only by the cost of the actual damping material but also by the position of the material within the cabinet. The optimum position is always a compromise governed by the following considerations.

At the primary resonance determined by the length (the longest dimension) of the cabinet, the air molecules move parallel to the long axis, the sound intensity being a maximum at the two ends of the enclosure and a minimum at the centre. Most materials dissipate sound by reason of the frictional losses due to the air moving in the pores of the material, the losses being a maximum when the sound strikes the surface normal to its face. A sound wave moving parallel to the surface of a nominally absorbent material suffers little loss. Thus a given amount of material will produce the maximum damping of a particular resonance when it is mounted at right angles to the axis of the wave and at the point where the air particle velocity is a maximum. (See Fig. 10/1 B.)

At the primary resonance the particle velocity is a maximum in the middle of the length and zero at the ends of the enclosure and thus it is to be expected that the minimum amount of material will be required to achieve any prescribed amount of damping when that material is placed as a partition across the centre of the cabinet. The maximum amount of material will be required if it is mounted on the walls because the air particle velocity is always zero at the wall surface. This last point is illustrated by the following measurements.

The Q of the enclosure was measured at the frequency of the basic "length" resonance (approximately 300 c/s), the cabinet being empty. This gave a Q of approximately 30. One, two and four sheets of expanded polystyrene $\frac{3}{4}$ " thick were mounted on the end wall in sequence and the Q measured for each condition. For the final measurement, one sheet of polystyrene was supported on spacers $2\frac{1}{4}$ " deep to bring the sheet into the position occupied by the top sheet of the group of four. One sheet of absorbent on the end wall was of little value in that it only reduced the Q from 30 to 27.5. Four sheets reduced the Q to 22 but a single sheet with a $2\frac{1}{4}$ " air space behind it reduced the Q to 18 proving to be slightly more effective than four sheets of the material. Thus, by disposing the damping material in an effective position, three-quarters of the material could be saved.

Thus, if damping of the acoustic resonances of the enclosure is desirable, the least efficient position for absorbent is to fasten it directly to the cabinet walls, though this is the usual position for mounting.

It has been noted that the absorbent material will be most effectively used if it is placed at the point in the enclosure where the air particle velocity is a maximum. If the only resonance to be considered was the primary resonance due to the cabinet length, then

the most effective position would be the centre of the enclosure, the material being disposed in the form of a partition across the cabinet. However, this would be largely ineffective at the second harmonic resonance, for at this frequency the sound intensity is a maximum and the air particle velocity a minimum in the centre of the cabinet.

Material arranged as a partition across the centre of the cabinet would also be ineffectively placed to damp the "width" and "depth" resonances, for in both these the sound wave would be travelling parallel to the surface of the absorbent partition. It has been shown that all materials are ineffective absorbents when so placed.

An excellent compromise method of using an absorbent is to hang it in the form of a curtain from the top to the bottom of the enclosure, the curtain being spiralled through at least one turn in its length. When so mounted any sound wave must pass through the absorbent material in travelling between opposite walls and at every frequency some of the material is in a position where the air particle velocity is a maximum.

The effectiveness of this technique is illustrated by the following measurements. A quantity of acetate fibre was put into the cabinet, first as a four-inch thick layer over one end and then as a spiralled curtain. In layer form, the Q at the primary resonance frequency was approximately 18, whereas this was reduced to 6 when the same material was used as a spiral curtain. If it is correct to assume that the enclosure Q must be reduced to something in the region of six by absorbent material, then the use of a spiralled curtain is by far the most economical way of achieving the desired result.

Other Considerations

It is fairly well established that the addition of some damping material to a cabinet of small or medium size is generally advantageous in improving sound quality. Before proceeding further with an investigation into the optimum position for mounting damping material it is worth while considering why there should be any improvement, for the foregoing measurements appear to show that damping material as usually used is ineffective in reducing the main cabinet resonances.

An enclosure without damping reacts on the loudspeaker in several ways that are worth studying. A sound wave produced by the cone, moves outwards into the room in the usual way but it is followed by a second wave that has been reflected from the inside surfaces of the cabinet before passing through the cone and out into the room. The difference in time between the primary outgoing wave and the reflection from the inside of the cabinet is probably too small (in milliseconds it is equal to twice the cabinet depth in feet) to have any noticeable effect on the sound quality but it makes the measured frequency response look rather rough. The effect is

ABSORBENTS

almost completely suppressed by applying the absorbent material in the form of a bag round the speaker unit. In this position the reflected sound wave has to pass through the absorbent twice before getting out into the room, thus enhancing the effectiveness of the material in reducing the amplitude of the reflection.

There is an allied effect that is also eliminated by acoustic material placed in this position. Standing waves set up between the rear of the cone and the enclosure walls can increase the sound output from the cone at isolated frequencies where they arrive back at the cone in phase with the cone motion. Enclosing the speaker unit in an absorbent bag is an effective way of using the damping material, for again the reflected waves have to pass twice through the material before reacting on the cone.

Both these effects are illustrated by the frequency response characteristic shown in Fig. 10/1. Curve A was the response measured 3 ft. from the cabinet without any absorbent material inside it. Curve B was a repeat with the back of the speaker unit covered by a single layer of polyurethane foam, while Curve C was taken with the entire space packed with as much foam and acetate fibre as could be inserted. It will be seen that a single layer of material covering the back of the speaker unit is almost as effective as a completely filled enclosure, but the output below 100 c/s is reduced slightly.

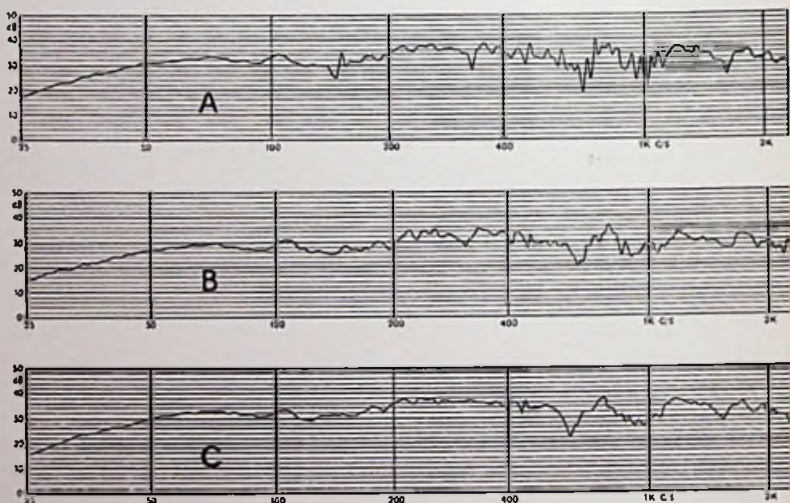

FIG. 10/1. *Open-air response curves of 12" roll surround unit in 1.8 cu.ft. reflex enclosure.*

A — Cabinet without absorbent material.

B — Speaker covered by one layer of $\frac{1}{4}$ " foam plastic material.

C — Cabinet filled with acetate fibre and foam plastic.

Conclusions

There is no really significant difference as damping media between polyurethane foam and bonded acetate fibre and the choice could be made on the basis of cost, convenience in handling and inflammability. Expanded polystyrene is not quite so effective and its lack of flexibility is a drawback in some applications.

The material used for damping cabinet resonance is less important than the position in which it is mounted. There are two methods of using the material that are significantly more effective than others. These are:

- (a) Hang the material from the top of the cabinet in the form of a curtain having at least one spiral turn in its length.
- (b) Enclose the rear of the speaker unit in one or more layers of material.

The usual method of attaching the damping material to the walls of the cabinet is the least effective.

APPENDIX I MEANING OF THE PARAMETER Q

"Q", a shorthand form for "quality factor", is an indication of the increase in intensity produced by a resonance. If there is only one resonance then the increase in intensity is equal to Q. Thus a resonance with a Q of 10 will result in the appearance of a peak in the output at the resonance frequency 10 times (20 dB) higher than the general sound level. Q is closely related to a number of other performance criteria. Thus the bandwidth of a resonance between the points at which the output is 3 dB down is equal to Centre Frequency/Q. In the present example, the basic length resonance occurs at 300 c/s and has a Q of 30. Between the frequencies at which the output has fallen by 3 dB the bandwidth is

$$\frac{\text{CENTRE FREQUENCY}}{Q} = \frac{300 \text{ c/s}}{30} = 10 \text{ c/s}$$

J.M.

My thanks to Mr. Moir for letting some valuable light into the dark corners of small enclosures and clearing up some of the absorbing problems associated with them.

I find myself in full agreement with most of Mr. Moir's deductions and I heartily endorse the idea that absorbents should be used with intelligent moderation to suit particular cases. Although lining the walls of an enclosure is the least effective treatment, it is often good commercially and in many instances provides all the absorption that is required, especially if the size of speaker used is small in relation to size of cabinet. For instance, an 8" or 10" unit in the 1.8 cu.ft. enclosure would require less absorbent treatment than the 12" unit.

ABSORBENTS

As to the difference between polyurethane (plastic) foam and bonded acetate fibre, the latter costs less and stands up better to severe tropical climates, but in one shallow cabinet we found that a layer of plastic foam glued to the inside of the back panel seemed to improve the reproduction of speech. (Please don't ask me why!)

Mr. Moir proves by his tests and response curves that maximum absorption takes place when the sound waves pass through the material. For curve B, only one piece of polyurethane foam, $24" \times 24" \times \frac{1}{4}"$ was used. But on a listening test we find that covering the speaker unit in this way gives a slightly boxed-in tone colour to the reproduction and restricts the LF cone movement slightly, with a just audible loss of bass.

Expanded polystyrene, being light and rigid, is very convenient to use in some enclosures where only slight absorption is called for, but as Mr. Moir says, it is less suitable where optimum results are expected at minimum cost.

CONE RESONANCE

Finally, a word or two should be said about the main cone resonance due to the stiffness of the volume of air and the mass of the cone. This is very pronounced in small, completely sealed enclosures. We also have the two familiar reflex enclosure resonances shown clearly in Fig. 12/23, although with 12" units with open resonance below 30 c/s, the lower of the two humps is well below audibility.

Filling either type of cabinet with absorbent material reduces both the frequency and the Q of these resonances and can have a most important effect on results.

In Chapter 12 we refer to a 2 cu.ft. enclosure where filling with absorbents brought the resonance down from 67.5 c/s to 62 c/s. Mr. Moir's technical explanation of the reason is quite interesting and here it is:

When a sound wave travels in a gas, the sound energy tends to vary the temperature of the gas at the signal frequency. Under conditions in which the air can lose the heat as quickly as it is generated, the conditions are said to be adiabatic and the velocity of sound is about 344 metres/second. If the enclosure is tightly packed with a good thermal insulator (fibreglass, B.A.F., etc.) then heat cannot be lost and conditions are isothermal. The velocity of sound is then about 290 metres/second.

It is this change in the velocity of sound that lowers the resonant frequency. The decrease is proportional to the square root of the two velocities so that if the empty cabinet had a resonant frequency of 67.5 then it should be

$$\frac{67.5}{\sqrt{\frac{344}{290}}} = \frac{67.5}{1.09} = 62 \text{ c/s} \quad \text{when full,}$$

which is exactly what you found.

J.M.

This seems to prove that our methods of testing are as good as Mr. Moir's maths, or vice versa.

Testing absorbents in cabinets can be a slow and laborious business, with repeated removal and replacing of cabinet back, which must be firmly fixed in position for reliable tests. It is hoped that this chapter will provide some help and guidance to the amateur.

SUPPLY POSITION

It is important to the amateur that recommended materials should be freely available. We have ourselves supplied quite a lot of B.A.F., i.e. bonded acetate fibre, in convenient sheet form, but when our own source of supply of acetate fibre was suddenly cut off recently for a few weeks, we began to test materials which are in more common use and are therefore plentiful.

This brought us to good old-fashioned cotton wool, and I must say the listening tests were highly satisfactory. In order to test the supply/cost position for the amateur, I launched out on another shopping expedition in good old Ilkley, and I came away with one carton containing 1 lb. of hospital quality wadding at 5s. 4d., and another marked B.P.C. costing 7s. 5d. for 1 lb.

The cheaper box contained about 11 sq.ft. and worked out at approx. 6d. per sq.ft., whereas the dearer box contained $8\frac{1}{2}$ sq.ft. and cost about $10\frac{1}{2}$ d. per sq.ft. For maximum absorption the latter is probably the best buy, as the material is softer and thicker than the hospital quality and it is actually finer in texture than the standard B.A.F. One layer of the cotton wool about $\frac{3}{4}$ " thick would replace an inch layer of B.A.F., which is more expensive.

The cotton wool can be held in position by staples, adhesive tape or dabs of gluc. Some support is necessary to prevent it collapsing in a heap in the bottom of the cabinet, but care should be taken not to flatten the material unduly. (If the reproduction sounds a bit chesty, a medicated wadding such as Thermogene could be tried.)

POLYSTYRENE DIAPHRAGMS

We point out several times in this book that 12" speakers are difficult to house comfortably in small enclosures because internal resonances are heard through the large cone, and honking soon results. In a cabinet 7" deep, the main back-to-front resonance occurs at 900 c/s with a very high Q, and this frequency would also represent the second harmonic of a 14" dimension.

In an article in *Wireless World* in January 1962, I pointed out that these internal resonances can be masked by fitting an expanded polystyrene diaphragm to the 12" speaker along the lines indicated in Fig. 10/2.

ABSORBENTS



FIG. 10/2.

12" loudspeaker with $\frac{3}{4}$ " thick flat polystyrene diaphragm added to absorb enclosure resonances.

Patent applied for No. 46738/61.

The non-resonant nature and light density of polystyrene make this modern material an attractive proposition in this application, as its absorption coefficient, which is related to the density, varies enormously with frequency. The absorption of $\frac{3}{4}$ " thick polystyrene starts at about 700 c/s and is quite strong at higher frequencies, as the accompanying response curves clearly indicate.

The effect of adding a flat polystyrene diaphragm in the manner indicated is twofold:

1. The egress of the internal resonances above 700 c/s is impaired and "honking" is audibly reduced.
2. The fundamental resonance is lowered by about 5 c/s and the LF output is increased.

The net result is cleaner reproduction of speech and better bass on music. 12" units with polystyrene diaphragms will probably be available commercially by the time this book appears in print. A treble unit must be added and a simple crossover at 1,000 c/s is satisfactory.

HF ACOUSTIC FILTER

When a very efficient tweeter is fitted in a small cabinet facing forwards, the output is sometimes rather pronounced. This can, of course, be adjusted by fitting a normal volume control, but a very simple and almost cost-free move is to fit a very small piece of fine cotton wool, about 1" diameter, in front of the treble unit.

This mild acoustic filter can easily be glued to the inside of the mesh in the centre of the speaker opening, and it helps to achieve quite a noticeable smoothing off in response without cutting the HF output unduly.

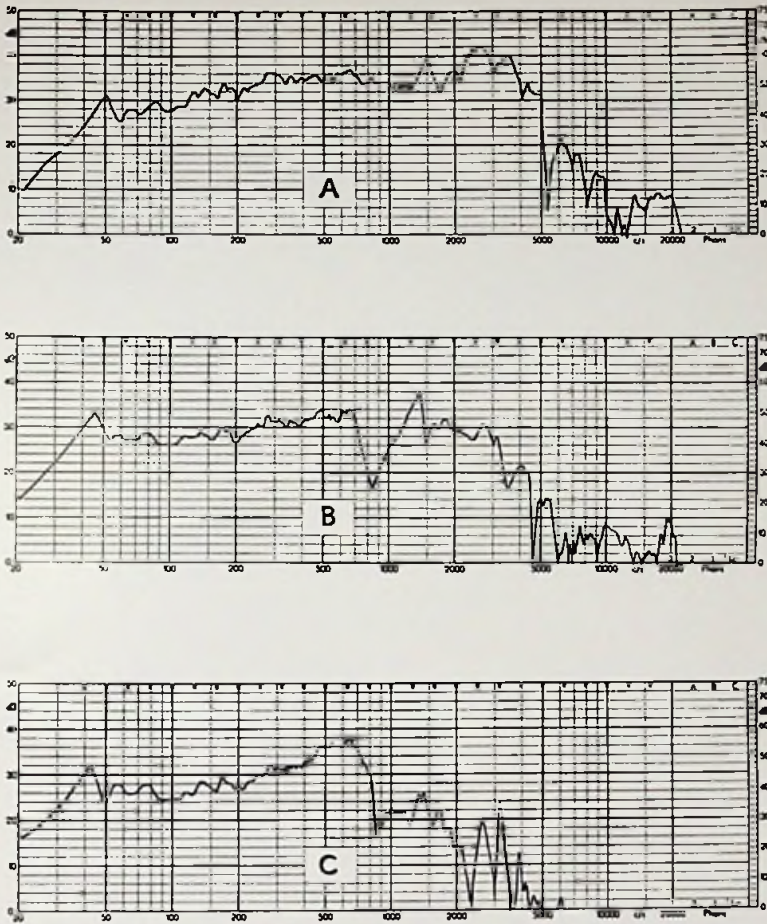

From *Wireless World*, Jan. 1962.

FIG. 10/3. *A* — Axial response of normal 12" speaker with airtight roll surround and suitable for use in average enclosures up to about 2,000 c/s.

B — Response curve to show the effect of adding $\frac{3}{8}$ " thick polystyrene diaphragm to the cone of speaker *A*. A crossover not higher than 1,000 c/s is necessary to avoid the junction effect at 1,500 c/s.

C — Effect of placing $\frac{3}{8}$ " thick polystyrene diaphragm in front of speaker *B*, showing sharp cut-off in response above 700 c/s.

CHAPTER 11

HOME EQUIPMENT

To construct the types of cabinet outlined in the next chapter with reasonable ease and satisfactory results, something more than the domestic hammer and saw will be required. I, therefore, asked our experts to draw up a list of minimum equipment; I also asked Mr. F. K. Dawson to illustrate the items, and we came through with Fig. 11/1 which I think is a credit to all concerned.

The key to the various tools now follows, with an indication of average cost which shows that, to set up as an amateur carpenter, an outlay of about £14 may be involved.

LIST OF TOOLS

	Approx. Cost		Approx. Cost
	£ s. d.		£ s. d.
1. Hand saw	1 5 0	13. Light hammer	6 6
2. Tenon „	17 6	14. Marking gauge	5 6
3. Pad „	6 6	15. Three-foot rule	10 6
4. Hand drill with bits	1 15 0	16. Mitre-cutting block	7 6
5. Half-round rasp	5 0	17. Combination square	17 6
6. 6" vice	1 7 6	18. Fine punch	1 6
7. 2" steel plane	2 1 0	19. Bradawl	1 6
8. Pincers	5 0	20. Stanley cutting knife	6 0
9. Ratchet screwdriver	8 0	21. Cork rubber	1 0
10. 1" chisel	10 0	22. Wing compasses	12 0
11. 4½" mallet	5 6	23. Sharpening stone	12 6
12. Hammer	8 6		

Also medium and fine sandpaper at about 4d. per sheet.

In addition to the items listed, a brace and bit outfit is often useful and an electric drill at around £8 saves time and energy. The handy electric sander has already been in orbit in Chapter 7.

Everybody knows what hand saws, drills, pincers, hammers, rules and compasses are used for, but some of the other instruments may be mysterious to the beginner, so we will briefly explain their purpose:

- No. 2. *Tenon saw.* For cutting rebated joints, mitred moulding, glue blocks, back rails, etc.
- No. 3. *Pad saw.* For cutting speaker openings and vents after boring a hole with drill.
- No. 5. *Half-round rasp.* Useful for smoothing edges of openings and over-hanging veneer.

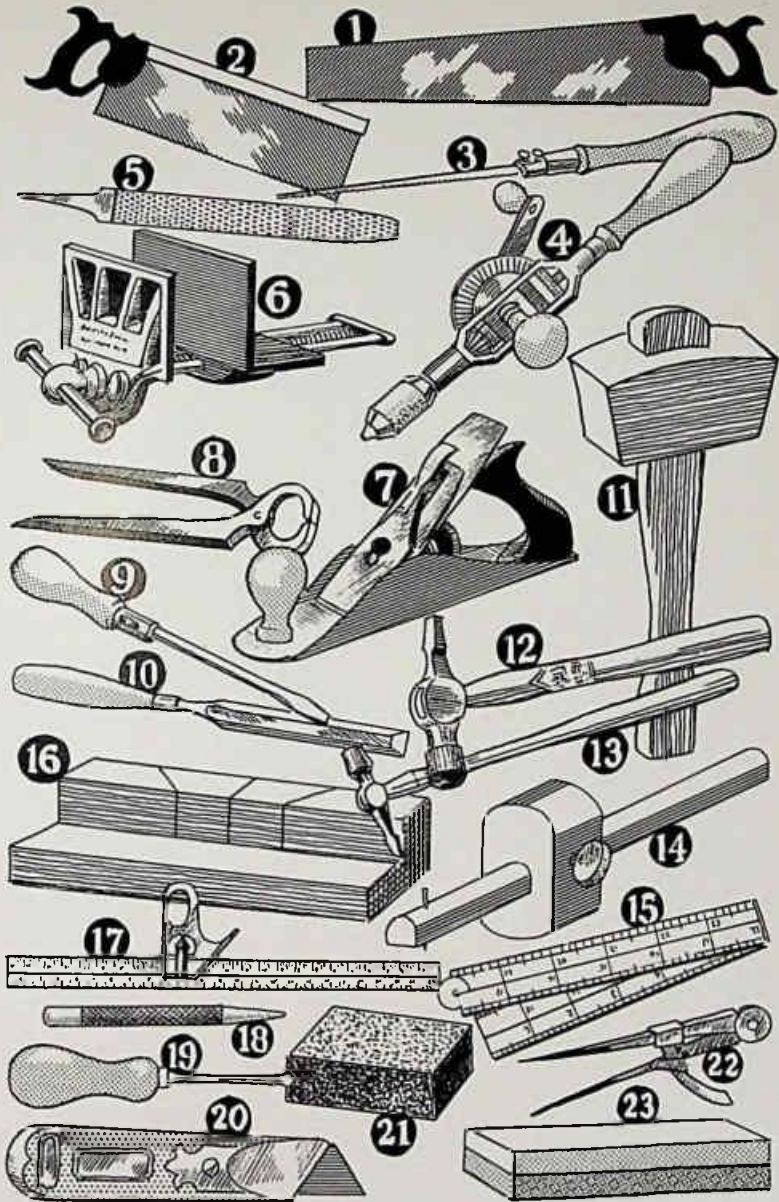

FIG. 11/1. Suggested range of equipment for cabinet making at home.

HOME EQUIPMENT

- No. 7. *Steel plane*. Use on solid wood and edges of plywood.
- No. 10. *Chisel*. Useful for removing layers of ply in rebates for joints. Also for cleaning edges of veneer instead of using rasp.
- No. 11. *Mallet*. Essential for hitting a chisel on the head.
- No. 14. *Marking gauge*. For scribing joints, rail positions, etc.
- No. 16. *Mitre-cutting block*. Almost indispensable for accurate corner moulding.
- No. 17. *Combination square*. Gives exact angles at 45° and 90°.
- No. 18. *Fine punch*. For knocking panel pins below surface.
- No. 19. *Bradawl*. Screw-hole maker.
- No. 20. *Stanley cutter*. For cutting veneer to size. Also useful in cutting ply for rebates in joints.
- No. 21. *Cork rubber*. To be wrapped with sandpaper.
- No. 23. *Sharpening stone*. For chisels and planes.

One important basis on which to work remains to be mentioned. That is a fairly solid bench or table. A kitchen table is suitable, but if not available for the work perhaps the best thing to do is to fit up the garage with electric light, central heating, an easy chair and some hi-fi equipment; then cabinet making can become an enjoyable pastime. (You will, of course, need a work bench.)

CHAPTER 12

CABINET DESIGN

We now come to the most important chapter in the book, as it is no use spending time and money producing beautiful cabinets if the acoustics are at fault. Anybody who has had practical experience of designing or testing different methods of mounting moving-coil speakers knows that the baffle or cabinet is almost as important as the performance of the speaker units themselves; in short, results can be ruined by applying unsuitable surroundings.

SMALL ENCLOSURES

The trouble is, of course, largely due to the adoption of small enclosures, mainly as a result of stereo and the space-saving cult. With a 9 cu.ft. corner specimen there is no problem. All you do is mount the speaker in it and add external treble unit(s) if there is too much bass or not enough top, and arrange directional or omni-directional effects according to taste.

So far as bass is concerned, the bigger the better is still a good slogan, but if compact enclosures have to be used, we must try to achieve the maximum performance. It is possible today to get results with 8", 10" and 12" units with linear suspension, which were unattainable a few years ago, and stereo helps to give more body to the smaller breed.

One major difficulty with compact reflex models has been that the volume and tuning had to suit the unit in relation to its size, resonance frequency and cone surround, otherwise the LF performance was unsatisfactory. Cone surrounds include cloth and foam which are not impervious to air, and corrugated and roll surrounds which are airtight. One of our main objects is to clear the air in this direction.

Enclosure Types. These can be classified under four headings as follows:

1. Open back cabinets;
2. Tuned reflex;
3. Distributed port or DP;
4. Total enclosure.

N.B. Horn loading is excluded because large flares are essential for good LF output.

Speakers which may be used in small enclosures can be broadly classified as follows:

CABINET DESIGN

Size: 8", 10" or 12".

Surrounds: Pervious or airtight.

Resonance: Below 30 c/s. Between 30 and 40 c/s. Above 40 c/s.

Response: Wide range single units or bass/treble combination.

According to my arithmetic (which is not very good these days) this set-up gives us 144 permutations and I am beginning to understand why this is my fourth attempt to write this chapter, which in turn indicates that it ought to be written to clear the air and help the amateur to decide what to do for best results.

Let us examine the four types of enclosure and consider some of their merits and limitations, with special attention to the less usual DP variety.

1. *Open-back Cabinets.* These have virtually gone out of fashion in hi-fi equipment during the last fifteen years, because the other designs usually improve LF output and wave form. Nevertheless, if you are troubled by honking in a special enclosure, and if the sides are shallow compared with frontal area, it might be worth while removing the back for a listening test. As the open back is placed closer to the wall, the bass response appears to improve—a distance of one inch being about the lowest reasonable limit. Any vent opening would, of course, be closed, as the speaker is performing like an open baffle.

2. *Tuned Reflex.* Properly adjusted and fitted with a suitable unit, the LF performance here in the $1\frac{1}{4}$ to 2 cu.ft. range is hard to beat, and larger enclosures are too well known to need any recommendation.

An important point is always the volume of air in relation to cone size. An 8" unit in 1 cu.ft. "sees" more air than a 12" unit in 2 cu.ft. because the cone area of the latter is about three times as big as the 8".

3. *DP=Distributed Port.* This amounts simply to fitting a slotted back instead of using a tuned vent or pipe. Fig. 12/1 shows the arrangement as adopted in one of our own 4-speaker systems a year or two ago. The cabinet is hexagonal in shape—which is quite good acoustically—and the bass enclosure amounts to 2.6 cu.ft. There are 17 slots in the back, each 8" long and $\frac{1}{4}$ " wide, covered inside with soft woollen cloth. The LF performance is good down to a frequency below the open baffle resonance of the 12" unit which is fitted.

It is obvious that the distributed port does not give a resonance as low as the bottom resonance of the tuned enclosure and the vent resonance is missing, but the higher main reflex resonance is avoided, and the reproduction is therefore rather cleaner and this shows up on speech.

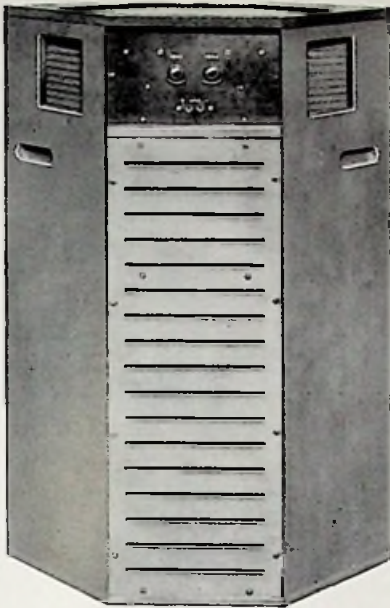

FIG. 12/1.
*Back view of hexagonal cabinet
 with distributed port to a
 2.6 cu.ft. bass enclosure.*

The advantages of the slotted back may be summarised as follows:

1. Any type of unit can be used, including cloth, foam, corrugated and roll surrounds.
2. There is no critical tuning; one slot more or less makes no audible difference to results.
3. Back-to-front internal sound reflection is reduced.
4. Resonance of back panel is also reduced and airtight fitting is not necessary.

Mounting a speaker in a DP enclosure raises the cone resonance frequency 10/20% but the Q is lower than the open baffle resonance and the wave form below this frequency is greatly improved. We now recommend the DP or slotted back design for the 1 cu.ft. and 5 cu.ft. enclosures, and it is quite practical for 3 and 4 cu.ft. volumes.

Fig. 12/2 shows the LF wave form at low input level with an 8" RS unit with open resonance at 60 c/s. At 40 c/s the note sounded pure, with slight frequency doubling at 30 c/s.

This performance was better than that obtained with a tuned 1 cu.ft. cabinet, and the general tone was more open.

This also shows that modern RS units with linear movement are capable of producing tones without serious frequency doubling at frequencies *below* cone resonance.

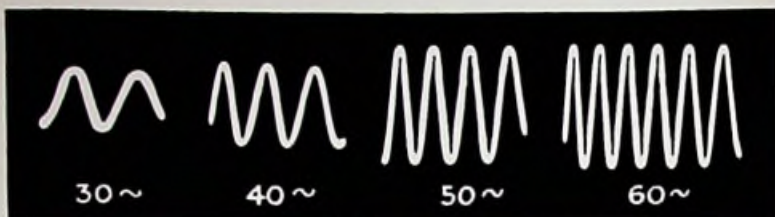

FIG. 12/2. Wave form with 8" RS unit in 1 cu.ft. enclosure with slotted back, placed 1" away from wall. Input 1 watt.

The impedance curves of Fig. 12/2A were taken with a 12" RS unit, 25 c/s resonance, mounted in a 5 cu.ft. DP enclosure, starting with 12 slots. It will be seen that reducing the number of slots approaches the conditions of total enclosure, which in this case would give good reproduction of mains hum.

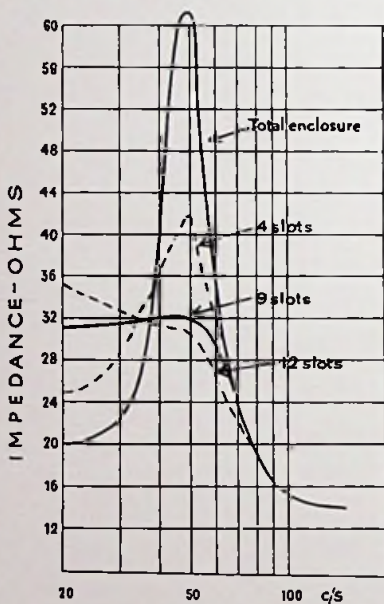

FIG. 12/2A. Impedance curves showing effect of reducing the number of slots in back of 5 cu.ft. enclosure, design as Fig. 12/8.

Other designs embodying the slotted back include the Airedale 3-speaker system, the Line Source models and the Stereo Satellite which comes into orbit later in the chapter.

4. *Total Enclosures.* Where an enclosure is small in relation to the size of speaker unit, complete boxing-in pushes the cone

resonance up quite a lot. A test with a 1 cu.ft. enclosure with tuned vent and 8" RS unit with a 60 c/s resonance produced the results shown in Fig. 12/2B, but it should be stressed that filling the enclosure with fine absorbent would have brought down the main resonance and its Q considerably.

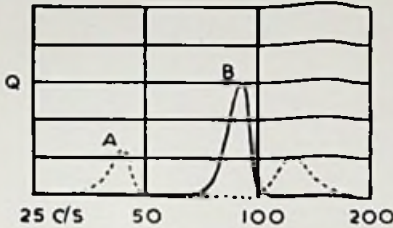

FIG. 12/2B.
Main resonances in 1 cu.ft.
enclosure lined 1" absorbent.
A — Vent open.
B — Vent closed.

With slotted back, the main resonance was 5 c/s lower than the total enclosure and the Q was 30% lower.

The two resonances at 40 and 110 c/s are preferable to a more pronounced peak at 90 c/s.

Another test with 12" RS unit, 25 c/s resonance, in a 2 cu.ft. total enclosure pushed the resonance up to 67.5 c/s with absorbent lining, or 62 c/s with complete absorbent filling. For best results here, a unit with open resonance below 20 c/s would be required. As these are not available commercially, we are not including small total enclosures in our designs.

GENERAL PERFORMANCE

The main problem is to get a good balance between bass, middle and top, and this can only be decided by a listening test on speech and music. A response curve often fails to expose many internal resonances which may colour the reproduction.

Studio transmissions of speech are usually very good, especially on FM, but different voices should be heard because of the wide variations in vocal resonance.

Although in theory a perfect loudspeaker should give natural reproduction of speech, with a point source, the requirements for choral, orchestral and organ works are somewhat different and for general purposes I would make the final decision or choice on music.

For a quick test of LF and HF performance, transient response and cabinet resonance, we find the record *Dimension in Sound*, Sharples, Decca SKL 4110, to be very useful.

One point to remember in judging results is that an increase in output above about 1,000 c/s seems to mask resonances at lower frequencies—hence my insistence at the beginning of this section on the importance of balance.

For a careful comparison of two speakers or two types of enclosure, the speakers should be placed side by side, otherwise wall

CABINET DESIGN

reflection, directional effects and room resonances may give quite misleading results, both at high and low frequencies. It is also advisable to change the listening position from time to time to sidetrack the standing wave effects in the room.

DESIGN DETAILS

In view of the importance of size, the main enclosures are classified in volume, beginning with 1 cu.ft. which is the smallest practical size for reasonable bass. In fact, it could be said that this simple and basic truth accounts for the existence and the success of the hi-fi speaker industry.

Some latitude is permissible in the designs so long as basic principles such as rigidity and internal volume are observed. The shape can be altered, but not to a square box, and there are pitfalls in adopting a larger area with a very slim back-to-front waistline. As a general rule, variations of 10% in dimensions are harmless. Where two or more units are used in one model, the associated networks are very important and may need adjustment to suit the particular speakers. (See Chapter 13.)

The types of speaker which suit the various enclosures are clearly specified. It is often a good idea to mount a speaker in a larger cabinet than the minimum indicated, but it is usually a mistake to reverse the order and squeeze a big speaker into a smaller cabinet.

1 CUBIC FOOT

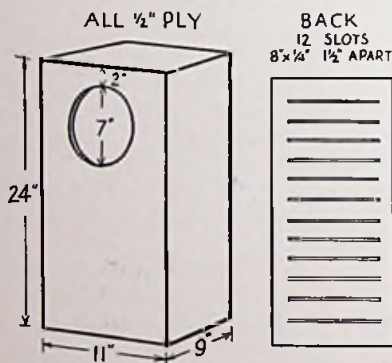
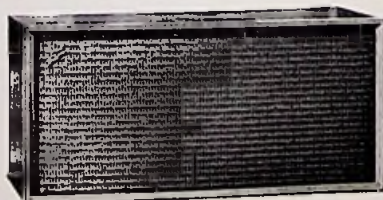

Fig. 12/3.
DP Cabinet suitable for all types of 8" unit.
Materials: $\frac{1}{2}$ " plywood lined on all four sides with 1" absorbent. Back lined with soft woollen cloth.
Weight: 14 lb. approx.

Finished appearance with solid wood frame and Tygan mesh.



Assembly of Back

For the home constructor, the slotted back is not so easy to make as a simple vent opening. The slots shown in our illustrations are cut out with a high speed router, but the amateur could assemble the back by using strips of plywood of the required width and fixing them firmly $\frac{1}{4}$ " apart to side battens. In all cases, the slots should be covered by soft cloth such as black melton, glued to the inside of the panel.

This cabinet can be placed on floor or shelf; an inch clearance from wall is adequate.

The enclosure can be converted to a tuned reflex by fitting an airtight plywood back and cutting a $9" \times 1"$ vent in the front panel.

This arrangement suits only 8" RS units with resonance around 40 to 60 c/s.

 $1\frac{1}{4}$ CUBIC FOOT

Recent developments in wall mounting cabinets of only $1\frac{1}{4}$ cu.ft. volume make it possible to obtain good LF performance with 10" and 12" RS units, using wall reflection to reinforce the vent output between 30 and 70 c/s. thus making up for the loss of floor reflection which occurs with wall mounting at a suitable height.

Two designs are shown—both reflex because it is desirable to make use of the wall reflections. Fig. 12/4 is a cabinet for wall mounting only, and Fig. 12/6 shows one which can also be placed on shelf or table.

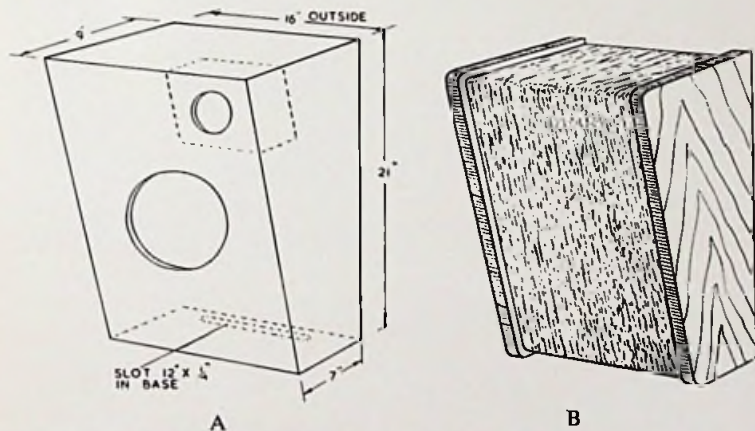

FIG. 12/4. *Wall mounting reflex cabinet with internal volume of about $1\frac{1}{4}$ cu. ft. Tweeter box optional.*

A — Diagram giving essential dimensions.

B — Suggested styling with Tygan coverage.

Materials: $\frac{1}{2}$ " plywood or chipboard for front and sides; $\frac{1}{4}$ " plywood or strong cardboard for tweeter box, which must be airtight.

$\frac{3}{8}$ " plywood lined $\frac{1}{4}$ " building board for cabinet back.

Weight: 16 lb. approx.

CABINET DESIGN

Units. The $12" \times \frac{1}{4}"$ slot suits $10"$ and $12"$ RS types with resonance below 40 c/s.

For an $8"$ RS unit with higher resonance, the slot should be enlarged to $12" \times \frac{1}{2}"$. In these small enclosures, the internal resonances are high and are heard mainly through the cone. They are therefore more prominent with a $12"$ unit than with an $8"$ or $10"$ size. With a $12"$ bass speaker and a separate tweeter, a crossover network helps to subdue the resonance effects. Full details are given in Chapter 13.

Absorbents. To suit results. Probably $1"$ lining to back and all four sides, plus two sheets $18" \times 12" \times 1"$ placed flat and loose in cabinet, using 7 or 8 sq.ft. of material in all. With $8"$ unit the required absorbent may be rather less.

The cabinet back requires special attention to avoid panel resonance and to ensure an airtight fit to cabinet sides. A combination of plywood and building board well glued and pinned together reduces resonance without increasing weight. For fitting, the best plan is to run $1" \times 1"$ softwood rails inside the cabinet $\frac{5}{8}"$ from back, firmly glued and screwed into position, cover with a layer of soft cloth and then fix the back with screws not more than $6"$ apart.

Wall Reflection. The narrow slot "tunes" the enclosure to a low frequency and is placed as near as possible to the back to obtain maximum reflection from wall, which doubles the output at 30 c/s as shown in Fig. 12/5. These are, in fact, sturdy little speakers as they perform best with their backs to the wall.

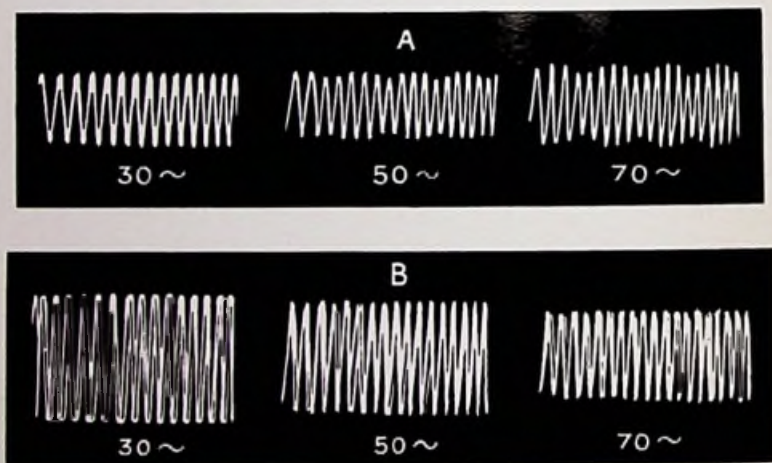

FIG. 12/5. Effect of wall reflection on output from long, narrow vent with $12"$ RS unit fed with warble tone from oscillator.

A — Cabinet $18"$ away from wall.

B — Cabinet with its back to the wall.

It is interesting to note that the maximum increase occurs at the lowest frequency.

Alternative Design. If a horizontal style is preferred, the design of Fig. 12/6 can be adopted and is, incidentally, also suitable for table or shelf mounting. The best assembly method for securing the extended sides has been shown in Fig. 6/5.

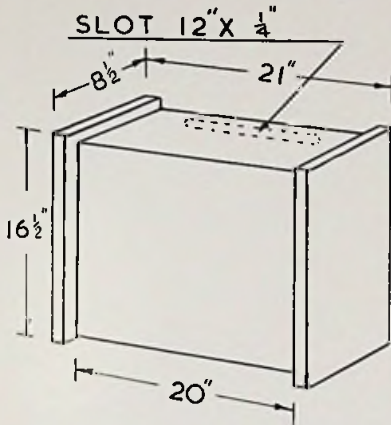

FIG. 12/6.
Alternative 1½ cu.ft. model suitable for wall or shelf mounting. Dimensions include protruding sides. Materials as Fig. 12/4.

The cabinet of Fig. 12/6 can easily be fitted with a tweeter box facing forward, or upward if less directional effects are preferred, or if they are required to match another omni-directional speaker on stereo. The tuning slot is placed in the top panel to remain clear if cabinet is placed on a shelf or table, and would be 10" × ½" with 8" RS unit.

The design of tweeter boxes and the associated crossover or coupling networks is very important in small enclosures and is dealt with in a separate chapter.

Fixing to Wall. Glass plates are the obvious choice, but as the cabinet and two units may weigh 20 lb. or more, the wall must be well plugged. We would recommend size 10 round-head screws at least 1½" long, securely held in the brick-work as distinct from the plaster.

It is a good plan to stick four felt washers, say ½" or ¼" thick and 2" diameter, to the cabinet back. These will avoid marking the wall, will give a measure of sound insulation and will also leave clearance for the speaker leads. Alternatively, these leads could be brought out through the narrow vent.

As to position on wall, I would recommend a listening and looking test before any wall plugging is indulged in. Room acoustics vary enormously, and so do furniture and fittings. With a bit of luck, it should be possible to find a position—not too high—where the speakers look happy and sound right.

2 CUBIC FEET

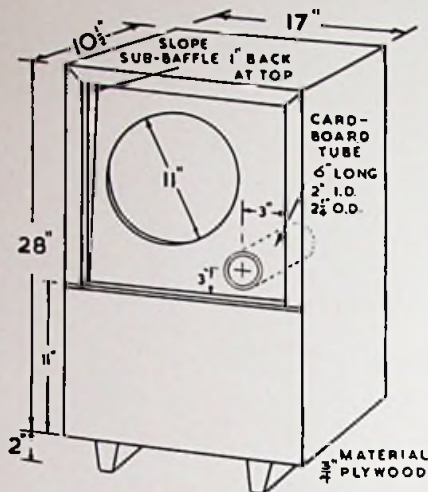

FIG. 12/7.

Fitted with a suitable RS 12" unit this reflex enclosure gives clean bass down to 25 c/s. The whole assembly—apart from the vent or port—must be airtight. Also suitable for 10" and 8" units, without changing slot dimensions.

Weight: 35 lb. approx.

Lining: 1" absorbent material (or more if required).

N.B. The tubular opening may be replaced by a slot 12" long, 3/4" wide, in the front panel or base of the cabinet.

Cabinet finished off with expanded aluminium mesh. The full Tygan treatment of Fig. 12/3 could also be adopted.

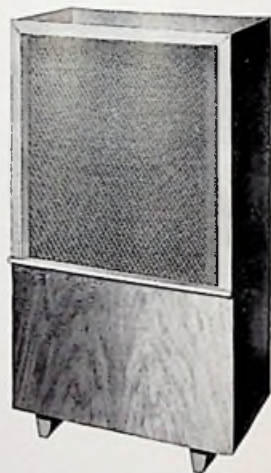

A tweeter box may be inserted with the treble unit facing forward or upward according to preference or to match another speaker on stereo. This will mean lowering the opening for the 12" unit and discarding the sloping sub-baffle, which in any case is not very important.

If a wide range 12" speaker is used here, the enclosure should be well filled with absorbent material. This is very important for clean results.

3 AND 4 CUBIC FEET

Now although the next drawing relates to 5 cu.ft. this does not mean that we have any rooted objection to cabinets of 3 or 4 cu.ft. The fact is that you can enlarge Fig. 12/7 and obtain better results provided you also increase the rigidity and avoid panel resonance.

The vent area would be enlarged to $12" \times 1"$, or the distributed port could be adopted with, say ten slots, each $10" \times \frac{1}{4}"$.

5 CUBIC FEET

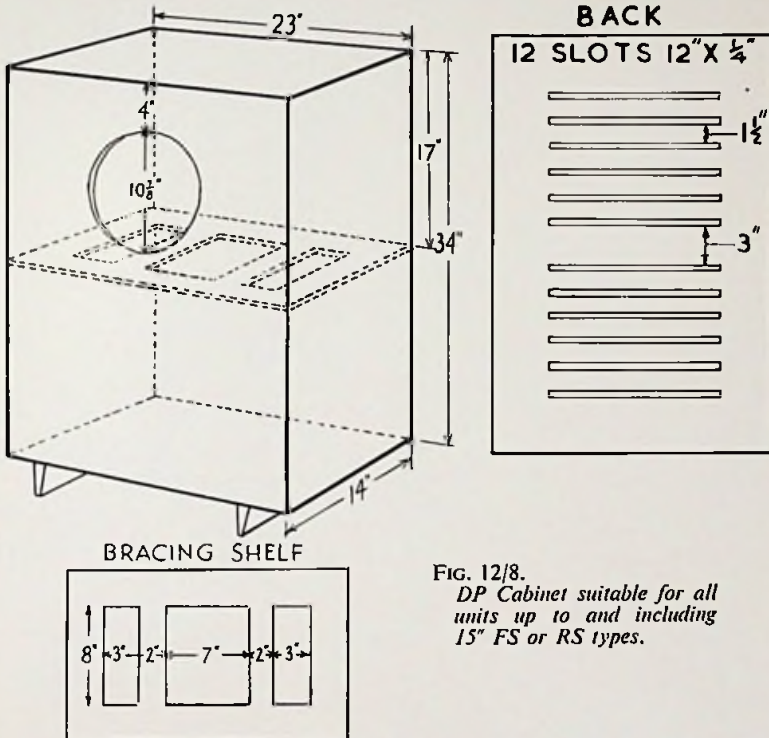

Fig. 12/8.
 DP Cabinet suitable for all units up to and including 15" FS or RS types.

Materials: $\frac{3}{8}"$ plywood, lined on all four sides with $\frac{1}{2}"$ Celotex or $\frac{1}{4}"$ building board. Back lined with soft cloth.

The bracing shelf must be secured around all four sides to cut down panel resonance.

Absorbents: One loop of absorbent wadding 7 ft. \times 1 ft. \times 1" thick, fixed to top of cabinet and passing through the two small openings of the bracing shelf.

Weight: 54 lb. approx.

A tweeter box, or external treble unit(s) on the lines of the Airedale, can easily be added.

9 CUBIC FEET

Designs and working drawings for sand-filled panels and brick enclosures are available free of charge from the publishers of this book, so we will not use up valuable space by repeating them here. There is no problem about good bass in this size.

The important point to remember when mounting a speaker in a thick panel or wall, is not to leave a resonant cavity in front of the cone. This can be achieved by adopting the arrangements outlined in Figs. 12/9 and 12/10.

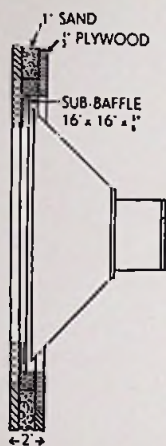
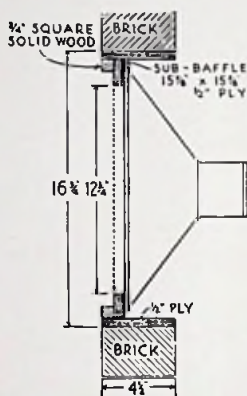

Diagram to show method of fitting sub-baffle to sand-filled panel.

FIG. 12/9.



Side view of brick panel showing method of fixing sub-baffle.

FIG. 12/10.

AIREDALE

Under this rather doggy name, we have produced a mobile version of the large corner 3-speaker system which can be useful on stereo to match a fixed corner system. Although difficult or probably impossible to make at home, we are including drawings as they may be helpful to readers in more remote corners of the earth.

Resonance is avoided by a combination of sand filling and ceramic tiling, and the acoustic lay-out matches the ideas adopted in the previous corner systems.

This speaker system is fitted with a half-section crossover network with the main crossover at 400 c/s. The unit is mounted on its side behind the middle and treble speakers, with the controls facing to the back. Circuit on facing page.

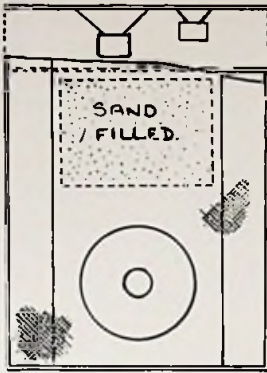
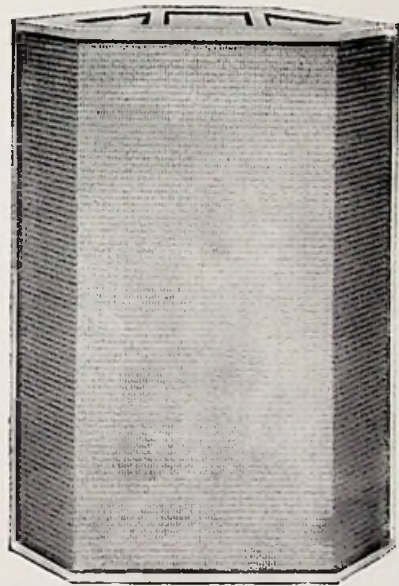

FIG. 12/11.
 Drawing to show the acoustic lay-out for the three units used in Fig. 12/12, with sand-filled front panel.
 Volume of bass enclosure 5 cu. ft. approx.
 See Figs. 12/13 and 12/14 for working drawings.

Absorbent: One loop of material passing through bracing shelf as described under Fig. 12/8.

FIG. 12/12.
 Finished appearance of mobile 3-speaker system, with 15" RS unit and 8" and 3" middle and treble speakers.
 Half-section three-way separator unit with crossover frequencies at 400 c/s and 5,000 c/s.
 Size: 39" x 28½" x 14".
 Weight: 91 lb. complete.
 Impedance: 12/15 ohms only.
 Max. Input: 20 watts RMS or 40 watts peak.



Individual controls for middle and treble response are located in the rear panel.

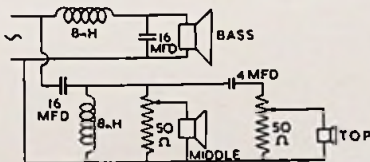

Half-section crossover network with two controls, as used in Airedale speaker system, with 10/15 ohm units.

CABINET DESIGN

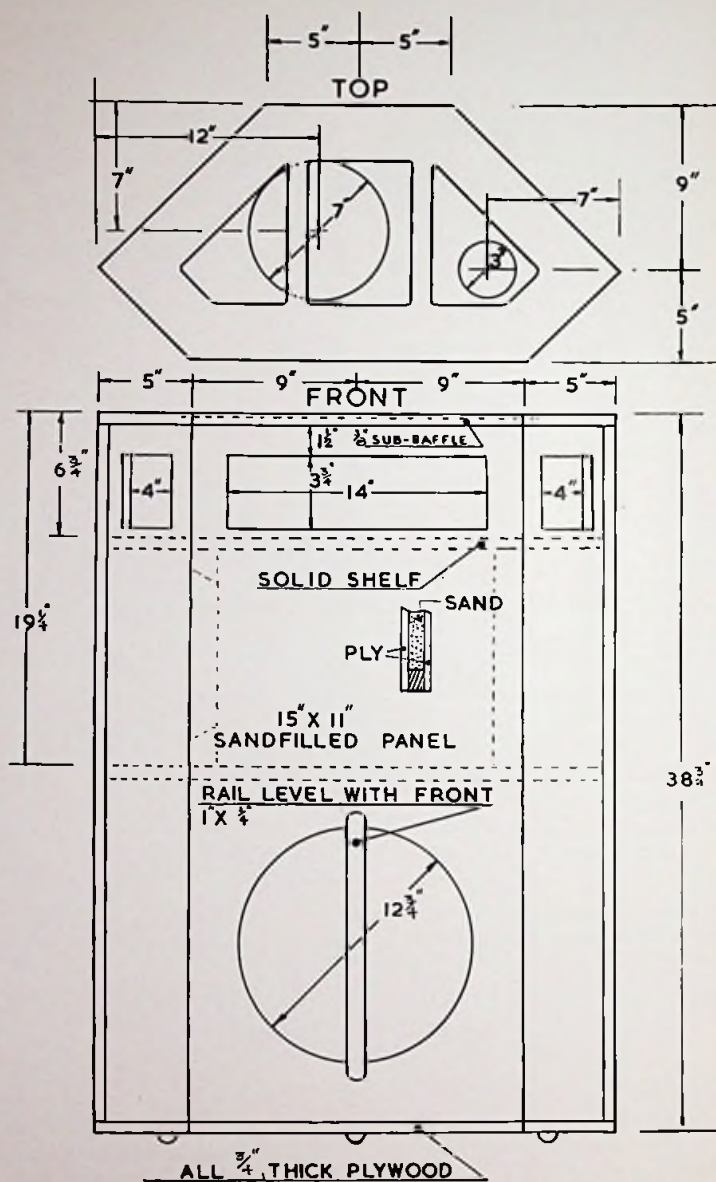

FIG. 12/13. Front and top panels of Airedale cabinet. Section above 15" speaker is sand filled.

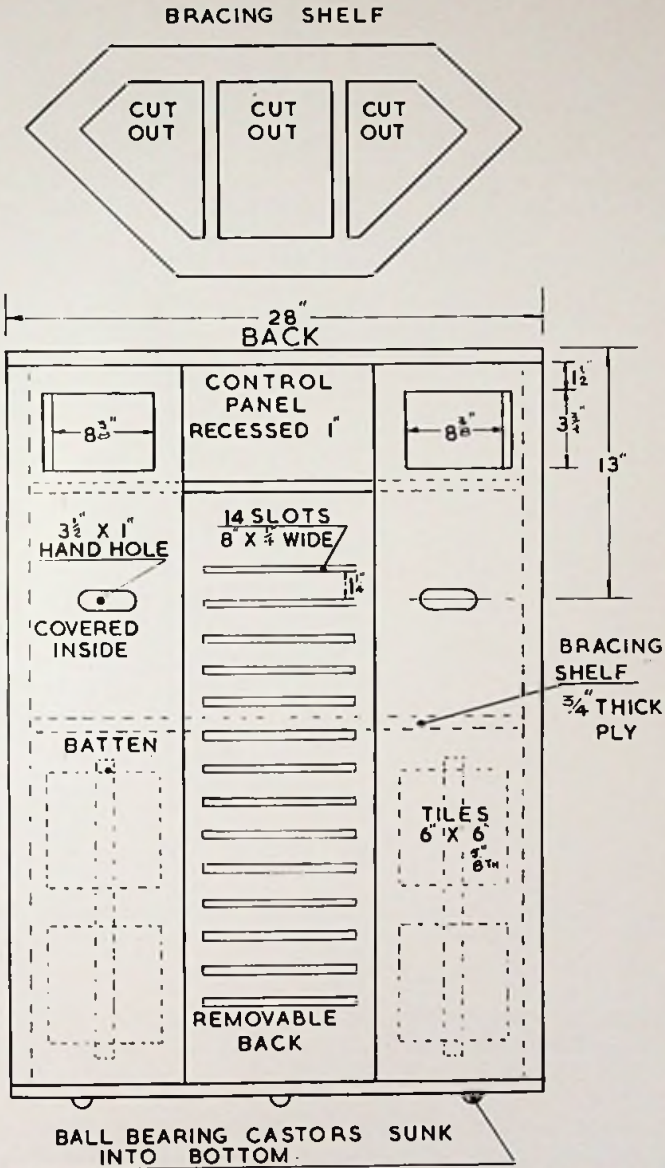

FIG. 12/14. Back panels and bracing shelf. The two side panels are lined with tiles to reduce resonance.

OPEN BAFFLE

The only objection to the good old open baffle is that a large area is required to maintain the LF output. A useful medium size has already been illustrated in Chapter 1, but for fuller bass a size of about 3 ft. x 2½ ft. is required. Fig. 12/15 shows a design suitable for a 15" bass unit with 10" or 8" speaker connected in parallel and preferably a 3" tweeter mounted on a small baffle behind the large panel and facing upwards, via the usual 4 Mfd capacitor and volume control. Quite good bass is also obtainable with a combination of 12" and 10" units in parallel, *and of course in phase.*

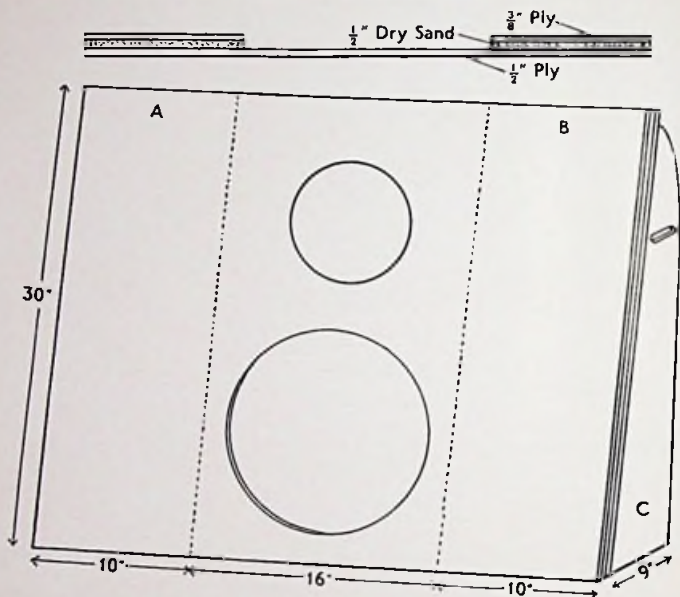

FIG. 12/15. Sand-filled baffle for home construction to take two closely coupled units, with tweeter at the rear if required. Sections A and B are sand-filled.

If there is too much "middle" in relation to bass, fit a volume control to the 8" or 10" unit, or a 4 mH inductance in series with the 12" or 15" speaker, or apply both remedies!

LINE SOURCE

There can be no doubt that for controlled reproduction of speech, especially under difficult acoustic conditions, the line source design is the best. A good illustration of this is to listen to the tin trumpet PA system at Kings Cross station and then travel to Leeds and hear the line source results with the sound directed towards the people

and away from the domed, reverberant roof. The difference is remarkable, but I am not suggesting that the test justifies a 200-mile journey by British Railways.

A design using 6 units is illustrated in Fig. 12/16. The series/parallel connections of Fig. 12/17 will maintain the load impedance at two-thirds of the value of a single speaker.

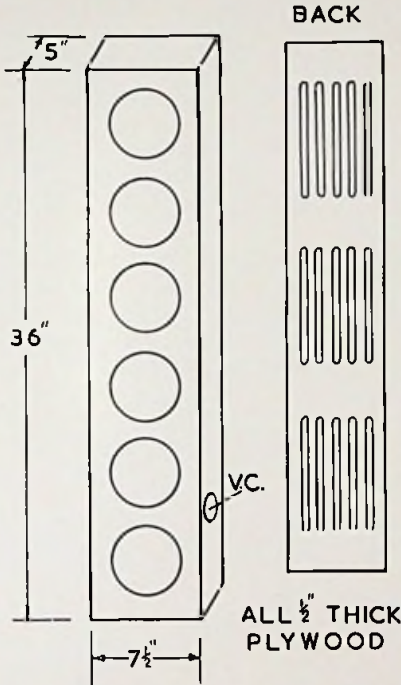

FIG. 12/16.

Line source cabinet for six 5" units. The inside of the back should be covered with thin black cloth, securely glued to plywood. Slots: 8" x 1/4"

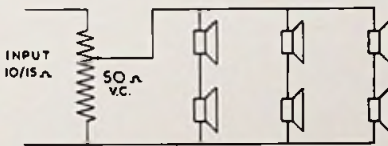

FIG. 12/17.

Series/parallel connection of six 15 ohm speakers, with volume control. Effective total impedance approximately 10 ohms.

The slits in the back of the cabinet improve the LF loading, and control the polar diagram in the treble where speech is important.

Naturally, any number of units from three upwards can be used in a line source design, and they may be 3", 4", 5", 6", 8" or even elliptical types. (The moving-coil speaker is, to say the least, rather versatile.)

CABINET DESIGN

The main acoustic objective with the line source design is to cover a wide area in front of the speakers in the horizontal plane with a limited coverage vertically, and this can be helped by cutting down the input to the end speakers in the long enclosure. The best way to do this would be to modify the circuit of Fig. 12/17 and use two controls as shown in Fig. 12/18.

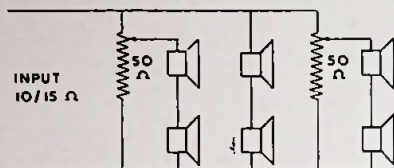

FIG. 12/18.
Method of reducing the output from the end speakers in a line source system.

This arrangement would give flexibility in control, the levels being adjusted to suit the conditions.

On the other hand, it may be necessary to extend the sound coverage vertically to reach rows of people in a balcony without the use of additional loudspeakers. This can be done by altering the shape of the line source cabinet to something like Fig. 12/19. A separate volume control to each pair of speakers could be a useful modification here.

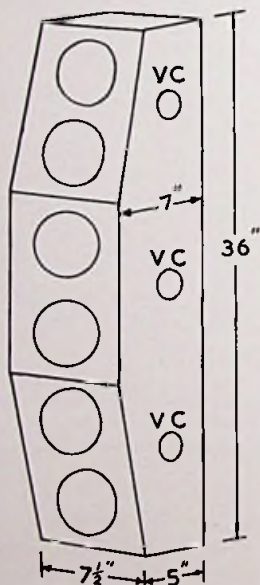

FIG. 12/19.
Line source speaker designed to reach rows of listeners at different heights, with three volume controls.

Mounted at a suitable height, such a configuration could cover a listening area to include stalls, circle and gallery.

Bass and Treble. Having been designed mainly for clarity on speech, the line source is not completely satisfactory on music, being somewhat deficient in bass. Where music is also required, it is a good plan to fit a 12" RS unit in a 2 cu.ft. cabinet, add a volume control and a simple 1,000 c/s crossover network and run it along with the line source model as in Fig. 12/20. Excellent results are possible under conditions which would normally prove to be very difficult.

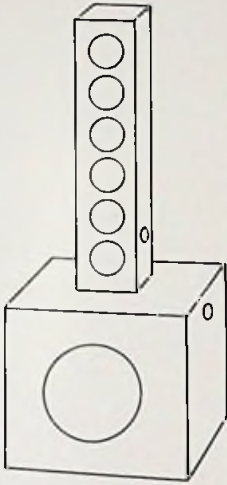

FIG. 12/20.

Combination of line source speaker with bass enclosure and separate volume controls giving maximum results on speech or music in classrooms, lecture halls, etc.

Crossover as Fig. 13/2 plus VC for bass speaker, mainly for use on speech.

COLUMNS

For omni-directional results and maximum LF output in relation to floor space occupied, column mounting for 8" and 10" units is hard to beat. The subject was fully covered in *A to Z in Audio* and working drawings are available post free from the publishers of this book, so we will leave it at that.

STEREO

The best arrangement for stereo is to have two speakers about 8 or 10 ft. apart. They need not be identical, provided the radiation pattern in the treble is similar.

It is not always possible to achieve the ideal in furnished rooms, but if the speakers are too far apart—say 15 or 20 ft.—there may be a "hole in the middle" effect, and if they are too close together the stereo effect is lost.

The simplest remedy is to place the bass enclosures in the most convenient position—wide apart in two corners or close together under a window seat—and use a couple of satellite speakers with a

CABINET DESIGN

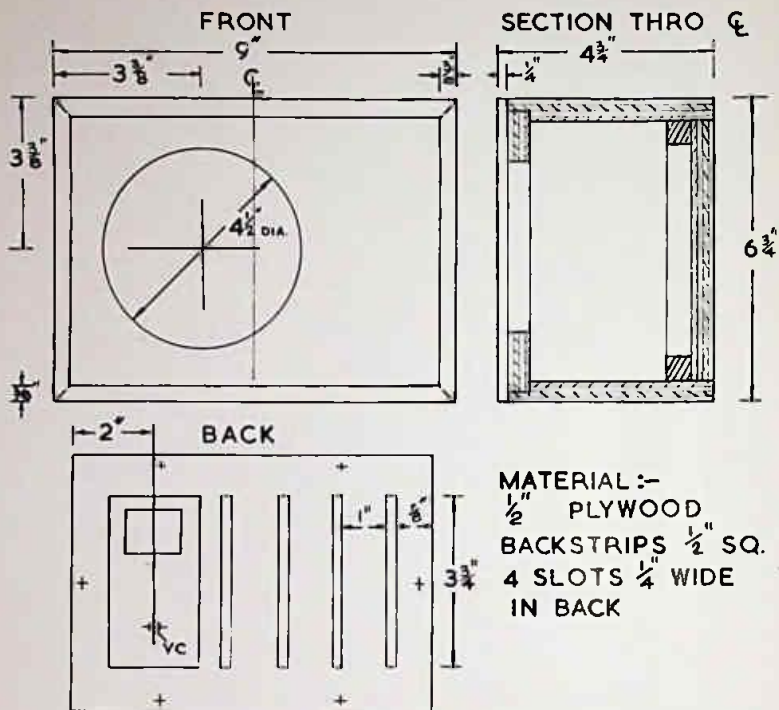

FIG. 12/21. Working drawing of cabinet to take 5" unit for response down to 400 c/s for use as stereo satellite speaker. 1/2" plywood or chipboard can be used.

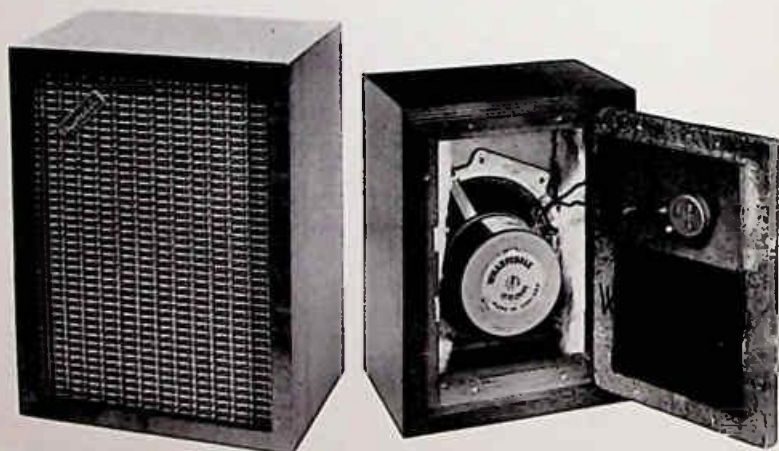

FIG. 12/22. Finished cabinet with view of interior; also volume control on back with black cloth covering slots.

crossover at 400 c/s. These can be quite small cabinets which are not difficult to place in a good position acoustically.

Fig. 12/21 gives all the details for a small cabinet with slotted back which will respond well down to 400 c/s and go up to 15 kc/s when fitted with a suitable 5" unit. Results on stereo are excellent with two of these suitably spaced at a height of 3 to 5 ft. The position of the bass speakers is not important because most of the stereo information is contained in the frequency range above 400 c/s. The two woofers could be wired up separately but actually housed in the same enclosure provided it is big enough. They would hardly know they were sharing the same kennel so far as stereo is concerned. (See *Double Bass* heading.)

The only other components are the two 400 c/s crossover networks which can be housed in the bass enclosures. Half-section types are the best, but quarter-sections work quite well.

DOUBLE BASS

We are often asked if it is a good idea to mount two speakers in a bass enclosure, instead of one. With the slotted back—which is similar to an open baffle—the answer is yes, as the larger radiating cone area and the mutual coupling between the two speakers result in a much bigger LF output. The units must be connected in parallel and in phase, the impedance being halved.

With tuned enclosures the position is quite different, and the entry of a second speaker may result in poorer bass unless the enclosure is large in relation to the size of units.

To get down to cases (no pun intended) let us take a look at what happens with enclosures of 1, 2 and 5 cu.ft.

A couple of 8 units facing forward in the small DP cabinet of Fig. 12/3 are quite satisfactory and give an audible increase of bass. They need not be identical; in fact, units of different resonance could be an advantage.

Moving up to the 2 cu.ft. tuned enclosure of Fig. 12/7, in which a 10" RS unit gives quite good bass with resonances at about 30 c/s and 90 c/s, the insertion of another 10" RS unit caused frequency doubling below 50 c/s and sounded worse on music than the single speaker. The fact is that each unit was only seeing about 1 cu.ft. of air loading instead of 2 cu.ft.

The effect on the impedance curve is quite interesting and is shown in Fig. 12/23.

Mounting the second speaker in the back of the cabinet for push-pull operation improved the LF wave form but still gave inferior output to the single unit.

The obvious way to use two 10" units in this size of cabinet is to convert it to the slotted back design, but I would *not* recommend two 12" units in this small enclosure even with extra slots in the back.

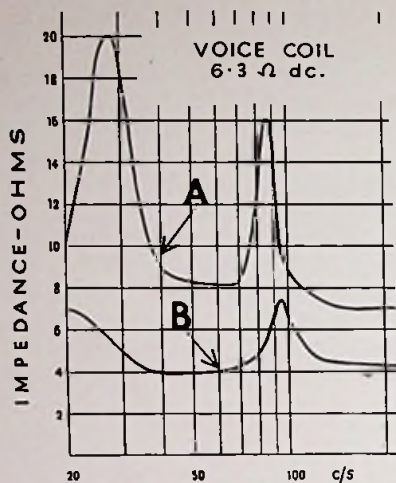

FIG. 12/23.

Impedance curves with 2 cu.ft. tuned enclosure.

A — Fitted one 10" RS unit.

B — Fitted two 10" RS units.

The resonance peaks in curve A are useful for boosting the bass.

The 5 cu.ft. model of Fig. 12/8 fitted with slotted back presents no problem. Two 12" units in our test gave more than twice as much LF output as one, and the quality was not impaired. The power handling capacity is also nearly doubled and the arrangement is worth consideration for use with electric guitars where overloading often occurs. The two speaker units could also be connected separately to stereo amplifiers and used with a couple of Satellites as explained under the previous heading in this chapter.

Now the 5 cu.ft. enclosure can be made into a very good reflex model by fitting an airtight back and tuning with a 12" \times 1" vent. It is big enough to work well with a couple of 10" units, but tested with a pair of 12" low resonance RS units facing forward, there was distortion at low frequencies and I would not recommend the set-up. A single 15" RS unit gave better quality.

With a 9 cu.ft. enclosure there is obviously plenty of room to mount two, or even three, separate speakers, but frankly speaking I cannot see any sense in doing it. Generous air loading increases the bass output and is in itself distortion-free, and once secured costs nothing to run and never deteriorates. And so I would say, if you have 9 cu.ft. of air loading on your bass speaker, stick to it.

CHAPTER 13

TREBLE ENCLOSURES

When using an 8" wide-response unit in a small or medium size enclosure, it is not as a rule necessary to add a tweeter, but if a 9 cu.ft. corner enclosure is used, the bass comes up and an increased response in the 8 to 16 kc/s octave may be needed to keep a good balance.

The circuit is already very well known, but is repeated in Fig. 13/1. The volume control may be omitted if the efficiency of the tweeter is not high in relation to its partner.

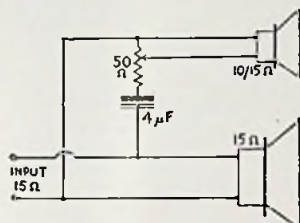

FIG. 13/1.

Tweeter with volume control. If the impedance of the loudspeakers is 2/3 ohms, the filter capacitor and VC should then be 12 Mfd and 20 ohms respectively.

The capacitor is essential to protect the tweeter from overloading with LF input. The reactance of the values most commonly used is as follows:

REACTANCE OF CAPACITORS

	500	1,000	2,000	5,000 c/s
12 Mfd	26	13	6.5	2.7 ohms
8 "	40	20	10	4 " "
4 "	80	40	20	8 " "
2 "	160	80	40	16 " "

It is clear that with 4 Mfd at 15 ohms the input at 2,000 c/s is cut by about 60%. Increasing the value to 12 Mfd will give fair input at 1,000 c/s and audible response at 500 c/s without damage to the tweeter.

With a 10" speaker there is rather more LF output than with an 8", and the decision about adding a separate treble unit would be taken according to results.

Turning now to the 12" speaker, which tends to expose the internal resonances of the 1½ to 2 cu.ft. enclosures, the addition of an isolated tweeter and a crossover network can make an enormous difference to results. The most convenient system for balancing the two speakers is a series inductance to roll off the treble from the

TREBLE ENCLOSURES

bass unit and a series capacitor to cut down the LF input to the tweeter.

Fig. 13/2 shows the values for 1,000 c/s crossover with 10/15 ohm speakers. With 5/10 ohms the values should be doubled for similar effects. The volume control is again optional.

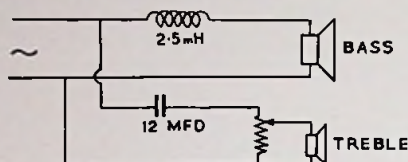

FIG. 13/2.
Simple system for control of two speakers in compact enclosure.

For slightly "drier" results the series inductance may be increased to 4 mH, or even to 8 mH which would start to roll off the bass unit very gradually (3 dB per octave) above about 250 c/s. On the other hand, if the response is smooth and maximum output is desired, the inductor may be omitted completely.

Reactance values work out as follows:

Coil	500	1,000	2,000	5,000 c/s
2 mH	6.3	12.5	25	62 ohms
4 mH	12.5	25.0	50	125 "
8 mH	25.0	50.0	100	250 "

By careful choice of network values in a compact two-speaker system a model which honks like nobody's business can often be smoothed out to give a reasonable balance on both speech and music, with of course the assistance of a judicious application of absorbent material.

TWEETER BOX DESIGNS

When a treble unit is added, this must be completely isolated from the sound waves produced by the main speaker. A tiny gap in the sides of the tweeter box or its junction with the large cabinet may produce objectionable buzzes and/or rattling sounds. The box should be made as small as possible so as not to waste valuable air loading space required for the bass speaker.

The design for a plywood box to take a 3" unit with large magnet is given in Fig. 13/3.

For more omni-directional results, the design of Fig. 13/4 can be adopted. The centre hole is made to suit the diameter of the speaker, then four extra openings about $\frac{1}{2}$ " wide are made so that sound waves are reflected from the inside of the tweeter box, which is designed with sloping sides for this purpose. No doubt some purists

and technicians will complain that out-of-phase effects will occur, but as these are going on in all listening rooms I think they must be accepted as part of the price we have to pay for enjoying music in an imperfect world.

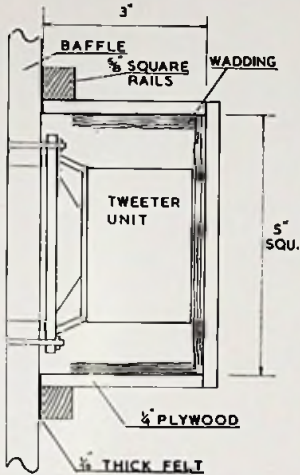

FIG. 13/3.
Assembly details for airtight enclosure for 3" unit with large magnet. The speaker leads are brought out through a hole which should be sealed off with adhesive tape to make it airtight.

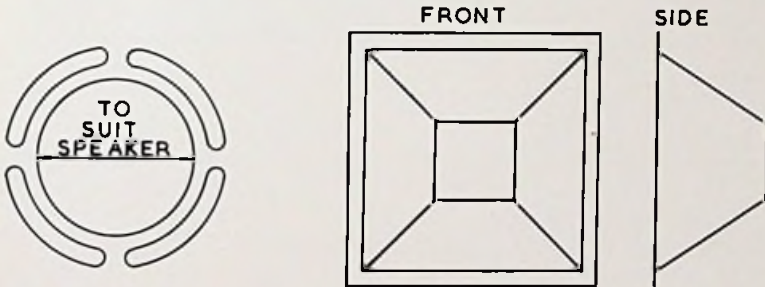

FIG. 13/4. *Tweeter box with sloping sides to reflect sound through openings 1/2" wide, placed around the speaker. Line with thin layer of absorbent material.*

This box or cover can be made by hand in strong cardboard, secured inside and outside by adhesive tape to ensure airtight joints. A layer of soft cloth or felt should be glued to the front rim before fixing the box in position—again to avoid any air leaks.

All components must be securely fixed in position to avoid vibration. Fig. 13/5 gives an inside view of a cabinet with a typical lay-out, including the reflector type of treble enclosure.

TREBLE ENCLOSURES

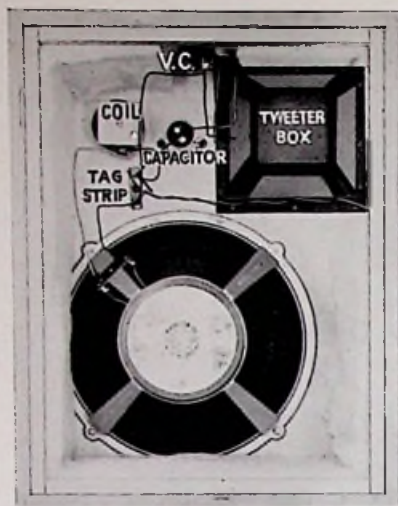

FIG. 13/5.
Cabinet fitted with 12" and 3" units, reflecting box, volume control, 2.4 mH coil and 12 Mfd capacitor.

Listening Test. When listening to a tuned enclosure, the back must always be firmly screwed on, otherwise peculiar effects may occur.

It is therefore a good plan to have the crossover components outside the cabinet when trying different values. The parts can then be placed in the cabinet when the circuit has been decided upon; they are too small to make any serious difference to the tuning.

CHAPTER 14

ELECTRIC GUITARS

During the last couple of years I have heard of more loudspeaker breakdowns with electric guitars than from any other cause in thirty years' experience of speaker making, apart perhaps from the early days of 1933/5 when relay speakers were made with high resistance voice coils wound with 46 swg copper wire which used to burst open in batches during local thunder-storms.

The reason is that the starting transients with a plucked string are very strong and the guitar microphone is so close to the sound source that overloading throughout the reproducing chain is easily induced. The organ is usually considered to be the instrument giving the severest test of LF power handling capacity in a speaker system, but I would say that the peaks from an electric guitar with the amplifier turned up are far more dangerous and are more likely to cause trouble.

Distortion and rattling noises may be due to one or more of the following causes:

1. Overloading of microphone and/or amplifier.
2. Excessive cone movement in loudspeaker.
3. Cabinet resonance with vibration of panels.
4. Vibration of objects and/or windows in listening room.

Cause 1 is outside our sphere of interest, but it seems to be quite easy to push 30 watts out of a 15 watt amplifier with a bass guitar.

As to cause 4, the only thing to do is to temper the wind to the shorn lamb and adjust the volume level to suit the room size. Only yesterday we were making tests in a demonstration room about 20 ft. \times 14 ft., where all sorts of rattling was heard at full volume; removing the guitar, the player and all the equipment to the open air also removed all the rattles, and entertained scores of people in the village of Idle, as the guitar could be heard half a mile away.

Causes 2 and 3 are very much up our street and it is because they occur so often that we are devoting a separate chapter to the subject.

In selecting speaker units for guitar work, it is advisable to forget all about free cone suspension, linear movement and soft surrounds, and go back to really firm corrugated surrounds which will withstand violent transient attack, using voice coil leads which combine strength with flexibility of movement. With a 15 watt amplifier I would advise the use of one 15" unit or a couple of 12".

Finally, the cabinet, which is at the moment our *raison d'être*. This must be much stronger and firmer than one used for ordinary purposes, otherwise it may produce distortion which can sound as

ELECTRIC GUITARS

though the amplifier or speaker units are faulty. Cross-battening of the larger panels and dowels between back and front are useful shock absorbers.

12" UNITS

If two 12" units are used, the best system is to mount them in push-pull, as this practically doubles the power handling capacity at low frequency. See Fig. 14/1. The voice coils are connected in phase so that the units both press inwards at the same time, and the tuned vent is replaced by a distributed port in the form of $\frac{1}{4}$ " slots in one side only of the cabinet—not both sides.

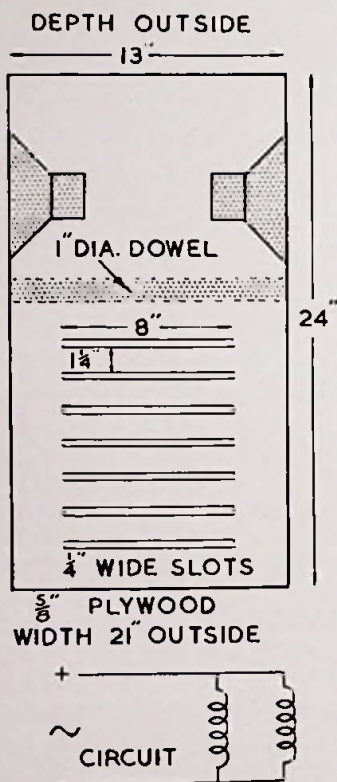

FIG. 14/1.

Side view of DP cabinet with 12" units mounted for push-pull operation. The speakers are connected in parallel and in phase but facing in opposite directions.

Volume: 3 cu. ft. approx.

Weight: 52 lb. with a pair of substantial 12" units.

Although the speaker units must be selected for maximum power handling capacity, the one facing forward could be a twin cone or double diaphragm type to improve the HF response, and this gives

better results with the standard electric guitar in which the frequencies go much higher than the bass guitar.

15" UNIT

For guitar use, the cabinet is usually required to be portable, but the minimum size for good results seems to be about 3 cu.ft. With a bass guitar, the frequency of the lowest open string is 41 c/s, and very good results are possible using a suitable 15" unit, open resonance 30/35 c/s, in a 3 cu.ft. tuned enclosure with outside dimensions 2' x 1' 9" x 1' 1", the vent opening being 4" x 3". Larger cabinets can of course be used, and the tuning becomes less critical as the volume is increased.

ABSORBENTS

As we have said, the important thing with guitar cabinets is to avoid panel resonance by rigid construction, but the use of absorbents to subdue internal acoustic resonances should be determined according to results. The more lively tone quality produced by cutting down or omitting absorbent treatment may well be preferred.

FUSE PROTECTION

The best way to avoid overloading a loudspeaker with electric guitars or any other input is to set the amplifier controls at a reasonable level. If the bass is turned up and the volume control is set at maximum, anything might happen with a high level input signal, and the speaker maker cannot reasonably be held responsible for results.

A good method of avoiding accidental overload is to fit a fuse in series with the loudspeaker. A fuse can be replaced for about 8d. in less than a minute and the controls can be adjusted to avoid further damage, whereas fitting a new cone and coil assembly may cost over £2 and takes at least a day or two to put in hand.

With a 15 watt amplifier and a 15 ohm speaker, a 500 milliamp fuse would be about right.

It should be remembered that if you push 30 watts out of a 15 watt amplifier, the 30 watts do not sound twice as loud as 15 watts, but they can do ten times the amount of damage.

Suitable fuses at various values between 250 and 1,000 milliamps are sold by all radio and electrical dealers.

CHAPTER 15

ROOM TREATMENT

Having gone to a lot of trouble to make a good speaker set-up for use in home, class-room or small meeting room, it would be a pity to mar the reproduction by unsuitable acoustic environments.

The main faults are usually excessive reverberation in large, sparsely furnished rooms, and eigentone resonance in rooms of domestic size. When reverberation is excessive, the sound takes a long time to die away and the trouble may affect a wide frequency range, whereas eigentones are directly related to room size and therefore occur at low frequencies, say below 250 c/s. Both faults can be tackled by the handyman without much difficulty.

REVERBERATION

Dealing first with reverberation, everybody knows that too much of it reduces intelligibility on speech, and tends to blur the reproduction of music because adequate reverberation is already included in recordings and radio transmissions. (With pop records there is often reverberation jam as well as butter.)

Excessive reverberation in listening rooms is caused by lack of soft furnishing to absorb the sound. Data on the sound-absorbing capacity of all the usual materials are given in the N.P.L. booklet entitled *Sound-absorbing Materials*. This is listed in our bibliography and costs only three shillings. The absorption curves used later in this chapter are taken from this source.

The following table gives a few typical absorption coefficients and shows that hard walls and glass have low absorption and therefore result in a long reverberation time. Acoustic tiles and carpet on foam rubber are very effective absorbers at about 500 c/s upwards, but the easy chair appears to be an easy winner.

ABSORPTION COEFFICIENTS

Material	Cycles per second					
	125	250	500	1,000	2,000	4,000
Brick	·024	·025	·031	·040	·050	·070
Concrete or stone	·010	·010	·020	·020	·020	·030
Plaster	·024	·027	·030	·037	·039	·034
Glass	·030	·030	·030	·030	·020	·020
Solid wood $\frac{3}{8}$ "	·100	·110	·100	·080	·080	·110
Plywood $\frac{5}{8}$ "	·110		·120		·100	
Perforated fibrous tiles $\frac{3}{4}$ "	·050	·300	·800	·800	·700	·600
Carpet, average	·050	·100	·200	·250	·300	·350
Carpet, on rubber	·150	·120	·550	·800	·750	·700
Chair, upholstered	2·500	3·000	3·000	3·000	3·000	4·000

From *Acoustics for the Architect*, by Burriss-Meyer & Goodfriend.
Published by Reinhold, N.Y.

In the average-sized room, curtains of velvet (or of similar weight/sq.ft.), a floor half carpeted, a settee and two chairs (but not the tube and plywood variety) do all that is wanted. Curtains on two adjacent walls are the best because they ensure that all the resonance modes are damped.

Acoustic Tiles. These are very effective in mopping up excessive reverberation (and cutting down noise in offices, canteens, etc.). We do not wish to plunge into arithmetic here, so we will refer those who want to know the method of working out the amount of tiles needed to the book *High Quality Sound Reproduction* by James Moir. (See page 485 in the first edition or page 537 in the second edition.)

We have found that covering only 10% of a wall area makes a difference to the acoustics, but 25% would be a more average treatment. Really drastic absorption clarifies speech but takes the life out of music.

If the floor is hard, the tiles would be fitted to the ceiling, but if the floor is covered with a thick carpet it would be preferable to put the tiles on two walls at right angles, as recommended for curtains.

The tiles can be bought from timber merchants at less than 2/- each, size $12" \times 12" \times \frac{3}{4}"$, and are easily fixed in position with *Treetabond* or similar adhesive.

Typical tiles may have holes about $\frac{1}{2}"$ apart and $\frac{3}{16}"$ diameter. Fig. 15/1 shows the effect of using thicker tiles with deeper holes.

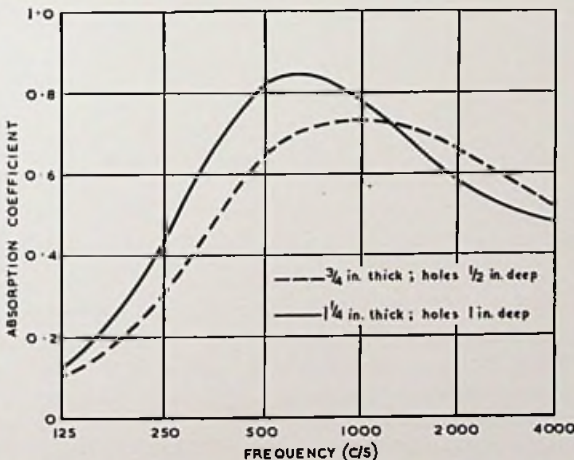

From N.P.L. booklet *Sound Absorbing Materials*.

FIG. 15/1. Perforated fibreboard tiles: effect of thickness and depth of holes.

N.B. Figures 15/1 to 4 are Crown Copyright and are reproduced by permission of the Controller of H.M. Stationery Office.

EIGENTONES

Turning now to furnished rooms of average size, the resonances due to eigentones occur at half a wave length (plus harmonics) and are sometimes mistaken for speaker resonance and often emphasise hum at 50 or 100 c/s. They work out as follows:

<i>Dimension</i>	<i>Main Resonance</i>	<i>Harmonics at approximately</i>
8 ft.	70 c/s	140, 210 c/s
10 ft.	55 c/s	110, 165 c/s
12 ft.	47 c/s	94, 140 c/s
14 ft.	40 c/s	80, 120 c/s
16 ft.	35 c/s	70, 105 c/s
18 ft.	30 c/s	60, 90 c/s
20 ft.	27 c/s	54, 81 c/s

A thick carpet with sponge rubber underlay helps to reduce the floor to ceiling resonance, and heavy curtains will absorb a lot of the horizontal type. In severe cases we can turn to plywood or perforated hardboard, and the curves of Figs. 15/2, 3, 4 and 5 show the sort of effects such treatment can give.

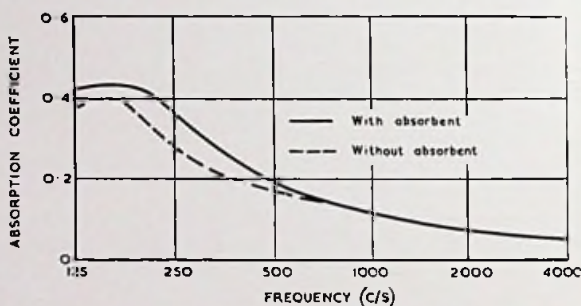

Courtesy N.P.L.

FIG. 15/2. Plywood panels $\frac{3}{8}$ " thick spaced 2" from wall. The effect of filling the space with absorbent is only slight.

To increase absorption above 250 c/s, perforations may be used.

Eigentones are exactly the same kind of acoustic resonance as occurs in speaker cabinets—discussed in Chapter 10. They are sharply tuned and for professional work would need resonant absorbers at the same frequency.

In domestic rooms, a more general treatment should be adequate. Where eigentones are objectionable, two or three panels 4 ft. \times 2 ft. with perforations and padding would improve results with some corner speakers or with open baffles and full range electrostatic speakers which are often very sensitive to room conditions. Fig. 15/5 (from 5th Edition of *Loudspeakers*) shows a suitable styling which would not look out of place in a furnished listening room.

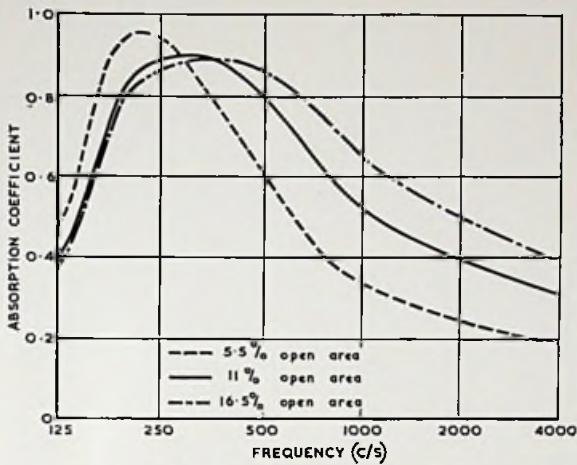

Courtesy N.P.L.

FIG. 15/3. Perforated plywood panels, $\frac{1}{8}$ " thick with $\frac{3}{16}$ " diameter holes, backed by $2\frac{3}{8}$ " thick absorbent.

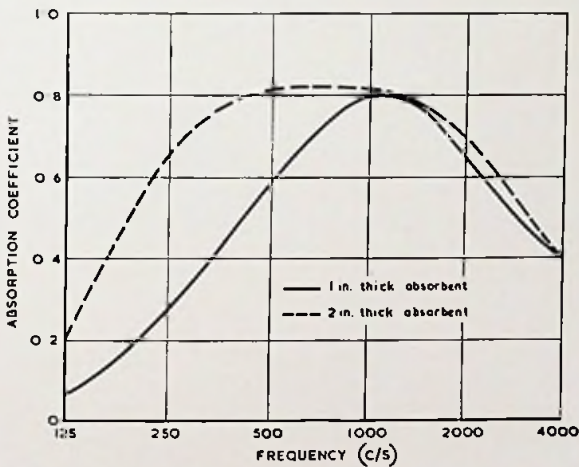

FIG. 15/4. Perforated hardboard panels, $\frac{1}{8}$ " thick, $\frac{3}{16}$ " diameter holes, 10% open area, showing more LF absorption with thicker padded space behind panel.



FIG. 15/5.

Acoustic absorber for wall mounting, size 4' x 2' Depth 4" at top; 1½" at bottom. Panel ¼" hardboard perforated with ⅜" diameter holes on ¾" centres. Inside filled with soft absorbent material.

Panelled Walls

We have seen that the absorption coefficient of plywood and timber is fairly uniform at all frequencies from 125 to 4,000 c/s and is about four times as high as plaster; also that spacing the plywood away from a wall increases the absorption at low frequencies, thus reducing the effect of eigentone resonance. I have actually heard very good reproduction in panelled rooms, and readers who have become skilled in woodworking might consider panelling a room, say two-thirds of the way up the walls from floor to ceiling.

Plywood $\frac{3}{16}$ " or $\frac{1}{4}$ " thick, not perforated, would be adequate, mounted on $2" \times \frac{3}{4}"$ battens, without the use of absorbents. Mr. Moir suggests that the panels should be of non-uniform size and thickness so that panel resonances do not all occur at the same frequency.

Since writing the foregoing I have had some concrete evidence of the soundness of the acoustic principles involved. (When I say concrete evidence I really mean panelled.) I rented a flat for the winter to cut down travelling in Yorkshire fog, snow and ice, and one room measured $16' \times 16' \times 11' 6"$, with leather chairs and thin curtains, and would have been acoustically hopeless but for the fact that the walls were panelled in varying sizes, à la Moir. The photograph, Fig. 15/6, gives a good idea of the panelling, which must be at least 50 years old.

Tapping the various panels shows wide differences in resonance frequency, which are all to the good.

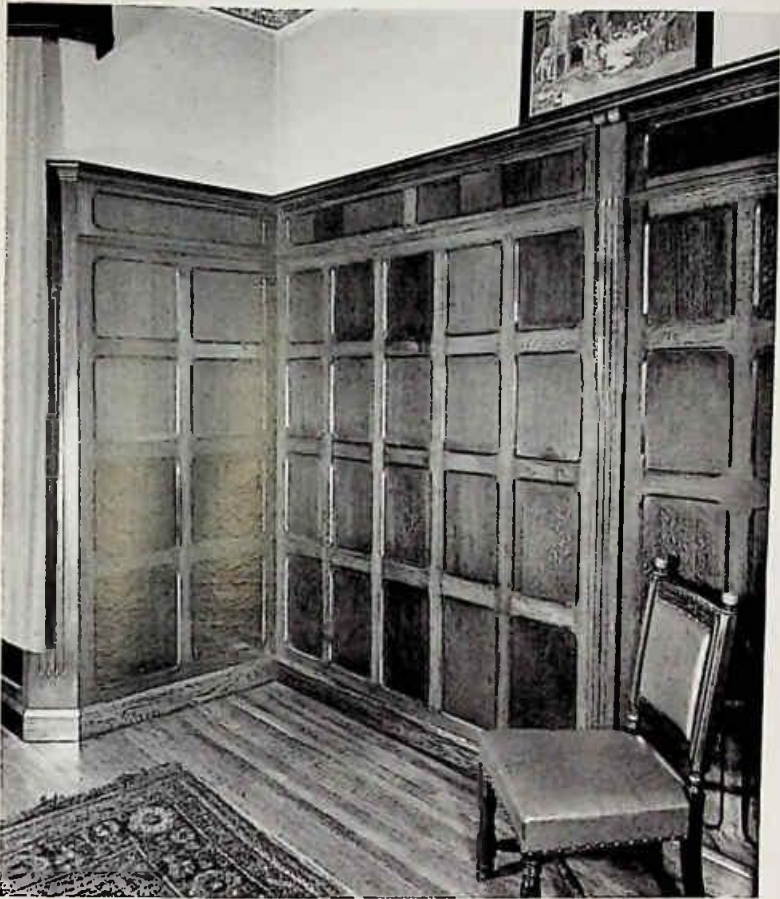

FIG. 15/6. *View of panelled room which gives very good reproduction of records in spite of being square and sparsely furnished.*

Although the acoustics of this room are not so good as my listening room at home, which measures $20' \times 14' \times 11'$, I am sure that the wall treatment makes a big difference to results and it is somewhat easier to panel a room than to alter its shape from square to oblong.

In writing about listening rooms, it is not suggested that most furnished rooms are unsatisfactory, but those who have given demonstrations in hotel bedrooms at Audio Fairs know what an enormous difference the room can make to results, the small, square variety being obviously pretty bad. A cube is worse, and many hotel bedrooms are not far off being cubes.

CONCLUSION

It is exactly thirty years since I began to dabble in loudspeakers, and I have always held the view that the final test of any domestic model should be a listening test, preferably under domestic conditions; from which it is a reasonable assumption that I have listened to quite a number—good, bad and indifferent.

It is, I find, exactly six months since we began working on this handbook, and I would say that during this period I have done more intensive listening to a wider variety of models than in any previous twelve months.

If I were to be asked what has impressed me most during these tests, I would say the almost miraculous way in which the addition of a tweeter or an increase in treble output masks boxy or boomy effects at low frequencies. An external tweeter is the best, but a boxed-in one is quite effective, and a volume control is recommended if the tweeter is more efficient than the LF or mid-range reproducer. (It should be remembered that some HF units are considered to be smooth because they are almost inaudible.)

Another development which has impressed me is the use of polystyrene diaphragms as acoustic filters; you could, in fact, make a very cheap crossover for an LF speaker by merely shielding it with a suitable thickness of sheet polystyrene! The density should be about 1 lb. per cu.ft.

The whole subject of acoustic treatment of loudspeakers, especially compact models, is extremely interesting and important. If this book helps the amateur not only to make cabinets but also to obtain the best possible results from them, it will have served its purpose.

March, 1962.

G. A. B.

INDEX

A	
Absorbents	14, 61-71, 99, 103
Absorption	70, 104
" coefficients	104
Acetate fibre	63
Acoustic absorber	108
" tiles	105
Adhesives	22, 26-28
Airedale	86-89
Assembly	42
" jigs	40-41

B	
Backs	44
Baffles	13, 60, 90
Barker, E.	7-8
Battens	44
Beetles	17
Belt sander	38
Bending	34, 39, 46
Bibliography	6
Blockboard	19
B.A.F.	61
Bostik	27, 56
Bricks	10
Broadley, E. R.	8
Building board—see	Hardboard

C	
Cabinet design	75
Capacitors	97
Casco contact	33
Celotex	58
Ceramics	12
Chipboard	14, 29, 58
Circular saw	37
Colron stain	48
Columns	11, 93
Concrete	11, 58
Cone resonance	68
Cotton wool	69
Cow gum	27
Crossover networks	87, 97-98

D	
Dawson, F. K.	72
Density	9
Diffusers	11
Disc sander	39
DP= Distributed port	
—see	Slotted back
Double bass	95, 102
Dowels	60, 102
Dry rot	16

Durability	23-24
Dural	13

E	
Edge veneering	33
Eigentones	106
Electric guitars	101
" sander	47
Expanded aluminium	53
" polystyrene	14, 63, 69

F	
Farnell, A. C., Ltd.	54
Filling	48
Finnish ply	21, 23-24
Frame work	45
French polishing	49
Fuse protection	103

G	
Glue blocks	43
Glueing veneers	24
Grading plywood	20

H	
Hardboard	14, 58, 81, 85
Hardwood	15
Heat treatment	56
HF filter	70
Home equipment	72

I	
Impedance curves	78, 96
Inductors	98

J	
Jamieson, W.	8
Jointing veneers	31
Joints	42-46

K	
Kelseal	58
Knots	21

L	
Lyall, R. R.	11
Line source	90-93
" " circuits	91-92

M	
Machines, general	36
" glueing	31
" jointing	31

INDEX—continued

Machines, sanding	38-39
" venereing	... 32
Marble panel	... 10
Materials	... 9
Mesh	... 53
Metal	... 12
Moir, J.	... 8, 61-68, 105, 108
Moisture	... 15-16

N

NPL curves	... 104-107
------------	-------------

O

Odhams Press Ltd.	... 16-17, 20
Oiled teak	... 50
Oscillograms	... 58-59, 78, 82

P

Panelled walls	... 109
Panels	... 30, 106-109
Perforated panels	... 107
Pests	... 16-17
Pipes	... 11
Plastic foam	... 63
Plywood	... 18
" sizes	... 25
" test	... 22
" thickness	... 25
Polishing...	... 47
Polyester	... 50
Polystyrene	... 14, 63, 69
Push-pull	... 102
PVA	... 12, 14, 26, 32, 39

Q

Q 61-69
-------	-----------

R

Reactance	... 97-98
Rebates	... 42
Refinishing	... 52
Reflector box	... 99
Reflex cabinets	... 76, 81, 83-84, 93
Resonance	... 13, 57, 62, 79
Response curves	... 66, 71
Reverberation	... 104
Room treatment	... 104
Rose, Norman (El.) Ltd.	... 54
Russell, K. F.	... 8

S

Sand filling	... 59-60, 86, 88, 90
Sanding	... 38-39, 47
Sealing	... 48
Slot diffuser	... 13
Slotted back assembly	... 81
" " designs	... 77, 80, 85, 89, 91, 94, 102
Softwood	... 15
Spraying	... 51
Staining	... 48
Stanley knife	... 30, 72
Stereo satellite	... 93-94
Storage	... 25, 35

T

T.D.A.	... 18-19
Tiles	... 12, 89
Tiny	... 12
Tools	... 72-74
Treble enclosures	... 97
Treetabond	... 105
Tropical ply	... 22-23
Tweeter box	... 99
" circuit	... 99
Tygan	... 54, 81

U

Uhu	... 27, 56
-----	------------

V

Veneering	... 29
Veneer cutting	... 20
" press	... 32
" storage	... 35
Vibration test	... 58-59
Volume controls	... 87, 91-92, 94, 97-98

W

Wadding	... 69
Wall mounting	... 81, 83, 86
" reflection	... 82
Wax polishing	... 49
Weyroc	... 14, 29, 58
White, R.	... 8
Wilkinsons (Bfd.) Ltd.	... 33, 37, 39, 42, 50-51
Wireless World	... 69
Wood worm	... 16